

Designing, Examine and Simulation of Wind Turbine Permanent Synchronous Generator

Md. Azam
Assistant Professor,
Dept.of Electrical and Electronics Engineering,
Anantha Lakshmi Institute of Technology and Sciences,
Ananthapuramu.

K.Venkata Subba Reddy
Assistant Professor,
Dept.of Electrical and Electronics Engineering,
Anantha Lakshmi Institute of Technology and Sciences,
Ananthapuramu

Abstract—Renewable energy-based battery charging systems for Electric Vehicles (EV) have seen surge in automotive research in last few years. Solar PV-fed EVs are thoroughly examined in this research. Among the many benefits of using batteries to store energy in ground vehicles include zero emissions, load levelling, excellent transient functioning, and ability to recover energy while braking. To meet these criteria, bidirectional DC-DC converter is needed to connect PV to battery's dc-link. A PV-powered electric vehicle must be able to operate in two distinct modes: charging and discharging. Maximum Power Point Tracking (MPPT) technique is utilized in this study to harvest most power by solar PV. In addition, DC-DC converter with bidirectional output requires closed-loop control circuit which is proposed in this paper. MATLAB simulations are used to confirm system's efficacy.

Keywords—DC-DC Converters, Electric Vehicle, , Renewable Energy.

I. INTRODUCTION

Growing environmental concerns, energy conservation, with global warming have caused shift toward developing industry in which renewable energy is seen as one of its strongest foundations by governments, businesses, and people alike. As an instance, EV has emerged as significant issue for both public and scholars [1]. In addition to wind and solar power, renewable energy sources also include hydel, ocean, and thermal sources [2],[3]. A power electronic converter including boost converter or DC-DC bidirectional converter may regulate flow of harvested energy and be used for wide range of applications [4], [5]. These converters are needed to harness these energies. Historically, SCRs were used to regulate all of these converters. A broad range of frequencies may now be operated by contemporary MOSFETs and IGBTs [6], [7]. Inductors and capacitors may be reduced in size and cost by increasing frequency [8]. Fast charging of batteries is also necessary in order to compete with petrol stations. This research demonstrates how an electric vehicle may be powered entirely by solar energy. Solar PV arrays are amongst easiest to install of renewable energy sources and ever decreasing cost of PV modules further adds to their appeal. As a result, PV array-based EV battery charging has become preferred method of charging for many EV owners [9], [10]. There's a requirement for an intermediate DC-DC converter as well as bidirectional DC-DC converter for combining PV array with EV battery[11]–[13].

Plug-in hybrid electric vehicles (PHEVs), fuel cell vehicles, and Uninterruptible Power Supplies (UPS) all use bidirectional DC-DC converters as an essential part of their power conversion systems. Using DC-DC converter is critical when switching from low-voltage battery to high-voltage source to charge household appliances. There are two types of bidirectional DC-DC converters: isolated as well as non-isolated. Non-isolated has higher efficacy because of its basic design. There's been several topologies published recently that use soft switching approach to improve efficiency of power transfer [14]. Soft switching by hysteresis current controller required introduction of bidirectional converter switch connected inductors [15]. Zero-Voltage-Switched (ZVS) and Zero-Current-Switched (ZCS) techniques were developed for bidirectional converters to reduce switching losses as well as increase reliability [16]. High power applications benefit from use of multiphase bidirectional converter. With low switching frequency, many converters may be linked in parallel or series to reach large voltage or current ratings [17]. For bidirectional converters using complimentary switching among topmost and bottom switches, unified current controller was presented [18].

Purpose of this study is to discuss usage of a bidirectional DC-DC converter in PV fed EV system. For functioning of converter in both buck (charging mode) as well as boost (discharging mode) modes, closed loop control approach is presented. Fig.1 is the schematic representation of PV-powered electric vehicle. It comprises of a PV module that is coupled to boost converter for boosting output voltage. Further DC-link is created in between boost converter and bidirectional converter for transferring the voltage. This bidirectional DC-DC converter is then connected to EV which is represented with a battery. This entire setup is made using MATLAB/ Simulink to test and validate the working.

II. CIRCUIT DESCRIPTION

Fig.2 depicts continuous conduction of DC-DC converter. Anti-parallel diode D1 serves as boost mode diode in this design, which modulates switch S2 to operate the boost converter. The anti-parallel diode D2 serves as buck mode diode when flow of power is reversed, transforming topology in buck converter by switch S1. The inductor current in two modes is going in opposing directions, as should be noticed. Fig.3 depicts gate drivers for switches S1 as well as S2.

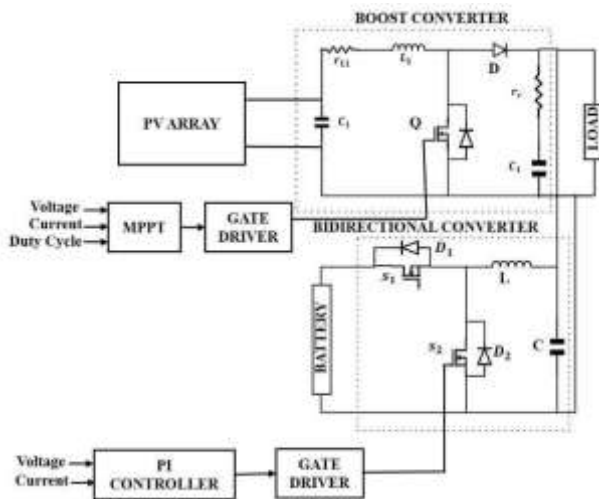

Fig.1.Schematic diagram of solar PV fed EV.

When converter is operating in continuous conduction mode, state space representation is represented in (1),

$$A \cdot \begin{bmatrix} I_L \\ V_2 \end{bmatrix} + B \cdot \begin{bmatrix} V_{L1} \\ V_H \end{bmatrix} = 0 \quad (1)$$

Where $A = \begin{bmatrix} \frac{-r_L}{F_L} & \frac{D}{L} & \frac{-1}{L} \\ -D & \frac{-1}{R_1 C} & 0 \\ 1 & 0 & \frac{-1}{R_2} \end{bmatrix}$

$B = \begin{bmatrix} 0 & 0 \\ 1 & \frac{RC}{1} \\ \frac{1}{R_2} & 0 \end{bmatrix}$

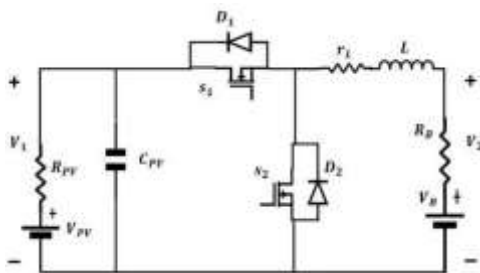

Fig.2.Bidirectional DC-DC converter.

A. Comparison with Previous Converters

Table I shows the comparison result of proposed converter with available bidirectional DC-DC converters. The parameters like switch count, inductor count, capacitor count, coupled inductor and common ground are the basic components that has dynamic role into designing converter circuit. Less number of components less will be the complexity of circuit. By table it could be observed that suggested converter requires very less number of switch

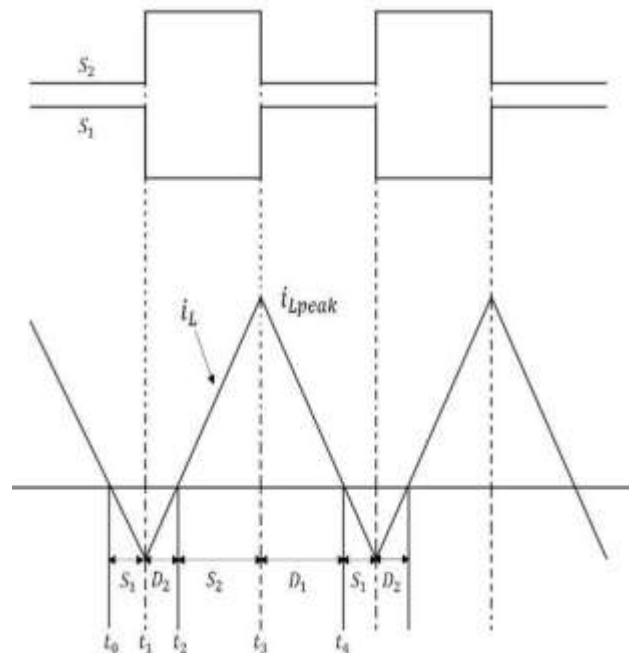

Fig.3.Gatedrivers for switches and diodes.

count as compared with [19]–[23]. The converter in [21] and [23] requires equal number of switch count. The converter [22] requires highest number of switch count. Another parameter is inductor count. The proposed converter, [19] and [20] require equal number of inductors. The converter [21] and [22] does not require any inductor. Converter [23] requires highest number of inductor count.

Similarly for capacitor count, [23] and [21] require highest number of capacitor. Proposed converter requires only one capacitor count which makes it simpler. As the proposed Converter is of non-isolated type, there is not any requirement of coupled inductor. Converter [22] uses coupled inductor in its circuit.

III. CONTROL TECHNIQUE

In this study, two types of control were used. In solar PV, most often utilized algorithms is Maximum Power Point Tracking (MPPT) method. Even though certain modules may be affected by shadowing, MPPT algorithm plays an important role in extracting optimum power from solar PV panel through out all times. Although certain modules have been obscured, remainder of battery pack will be energized to guarantee that EV functions properly. MPPT adjusts the value of solar PV power in line with the load or battery charger need. Another control method is for converter circuit.

Bidirectional DC-DC converters may operate in both buck - boost converter modes, hence control circuit has been built as illustrated in Fig.4. PI controller and PWM generator comprises responses closed loop control circuit block diagram, which detects and controls error signal in relation to reference signal. Inner current loop as well as outer voltage loop are part of control circuit. In the outer voltage loop, we calculate V_b (battery's voltage) as well as contrast it to V_{ref} . PI controller receives difference among two values. Using PI controller, steady state error among battery current being measured as well as reference battery current being monitored may be reduced or eliminated.

TABLE I. COMPARISON WITH VARIOUS PARAMETERS OF CONVERTERS

Converters	Proposed Converter	Converter[19]	Converter[20]	Converter[21]	Converter[22]	Converter[23]
Inductor Count	1	1	1	0	0	2
Capacitor Count	1	3	3	4	3	4
Coupled-Inductor	0	0	0	0	2	0
Common Ground	Yes	Yes	Yes	Yes	Yes	No

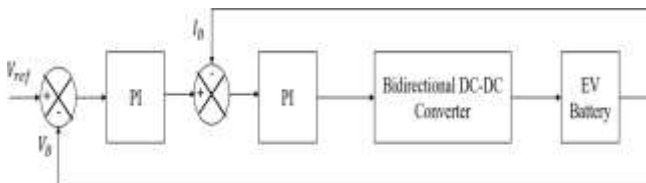

Fig.4. Closed loop control circuit for bidirectional DC-D Converter.

PI controller's transfer function is specified by

$$G(s) = K_p + \frac{K_i}{s}$$

Proportional as well as integral gains are denoted by notation K_p and K_i , respectively. Then return to current iteration of loop. Lastly, when compared to I_b (battery's current), difference is sent to PWM modulation via other PI controller. Stable PV voltage as well as steady EV current may be obtained via controller.

IV. SIMULATION RESULTS

In this section, the performance of the proposed model of Bidirectional DC-DC converter is analyzed utilizing the MATLAB Simulink platform. Figures below showing various parameters including the P V module voltage, current and corresponding power, DC link voltage, EV battery voltage, battery's State of Charge (SoC) at different level of irradiations on the PV side. It's not regarded inductor parasitic resistance or MOSFET turn-on resistance. To determine if suggested topology works, following converter parameter values are taken into account through out testing process.

Principal Parameters of the Bidirectional converter are: $L=500\mu H, C=1000\mu F, f_{sw}=5kHz$.

Battery capacity = 50 Ah, initial SoC = 45%, Battery nominal voltage = 24 V.

Fig.5(a) and 5(b) shows the battery voltage and battery current respectively with increase or decrease of the irradiation of the solar energy available to the PV module, that different irradiation levels of $0 W/m^2$ and $500 W/m^2$. In Fig.5(a) it can be seen that the battery voltage is increasing slowly with time that shows the charging mode of EV battery and same charging nature can be seen in terms of current in Fig.5(b), the decreasing nature of battery current. The Fig.6(a), 6(b) and 6(c) showing the voltage, current and power levels of a PV module at $500 W/m^2$ of irradiation and cell temperature of $25^\circ C$. Fig. 7 represents the irradiation level of $500 W/m^2$. .e.a DC link, with using Bidirectional DC-DC converter corresponding battery charging voltage as well as charge state of the battery can be observed into Fig.

8 that depicts the rising nature, showing the charging mode of the EV battery.

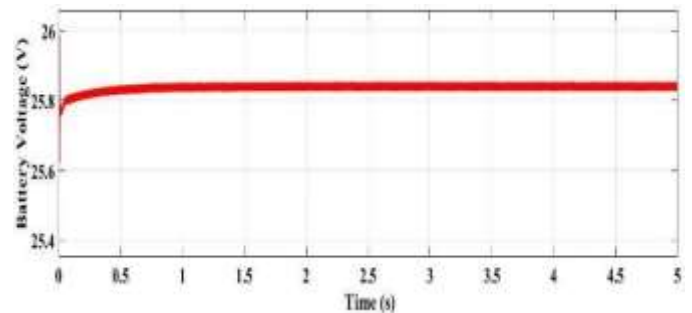

(a)

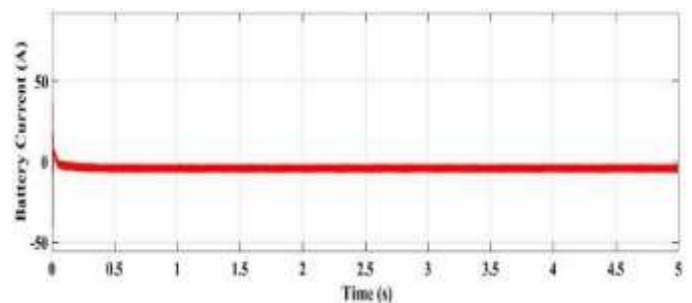

(b)

Fig.5. Battery (a) Voltage (b) Current with respect to irradiation of solar energy.

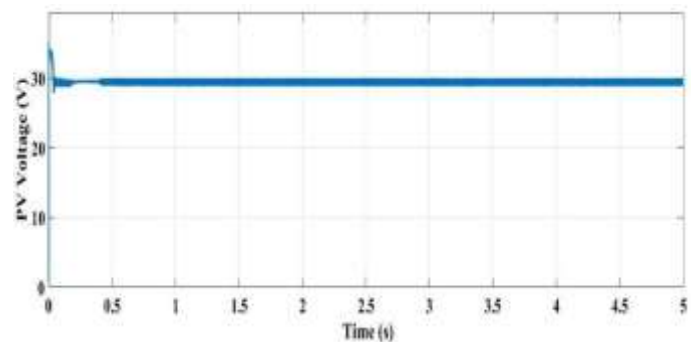

(a)

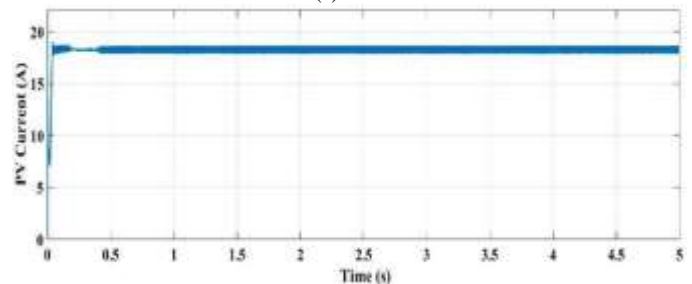

(b)

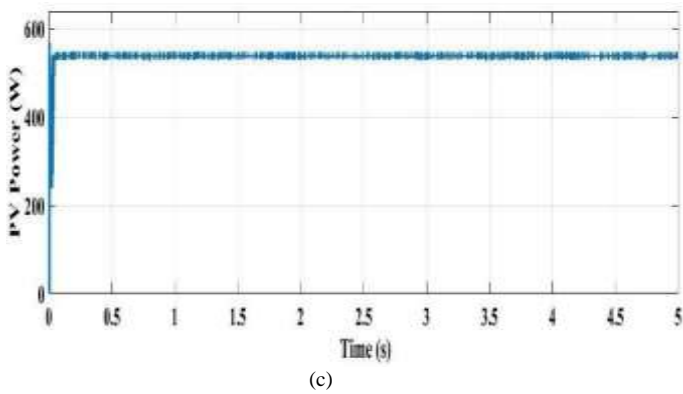

Fig.6.Solar PV (a)Voltage (b)Current (c)Power at irradiation of 500 W/m².

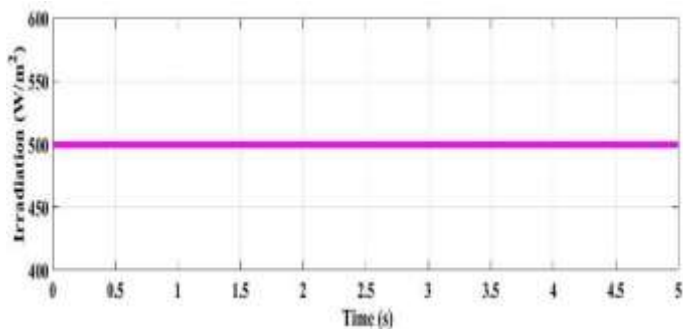

Fig.7.Solar PV irradiation at 500 W/m².

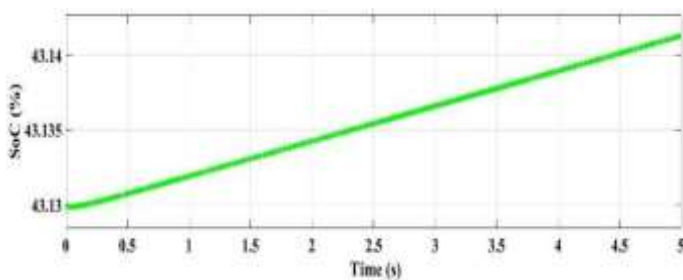

Fig.8.Battery SoC showing its charging mode.

V. CONCLUSION

Hybridized electric solar cars have become more popular in contemporary period because of their solar PV panels. An effective battery charging system and cost-effective EVs have resulted from recent technological developments in this field. This paper proposes the integration of PV panel with EV battery charging system through a bidirectional DC-DC converter. The converter circuit is compared by various topologies. The converter used in this paper does not require coupled inductor which makes the circuit more simplified. Also, the number of inductor and capacitor used are very less compared to these topologies. This converter operation is controlled through PI controller and switching of charging and discharging modes can be done. This battery charging is well-suited to PI controller control strategy that has been suggested. Additionally, MPPT algorithm is employed to harvest optimum power by solar PV under all different irradiation situations. EV's operation will not be disrupted in this way. DC-DC converter as well as control circuit have been shown to work as described in previous section.

REFERENCES

- [1] C. C. Chan, Y. S. Wong, A. Bouscayrol, and K. Chen, "Powering Sustainable Mobility: Roadmaps of Electric, Hybrid, and Fuel Cell Vehicles," *Proc. IEEE*, vol. 97, no. 4, pp. 603–607, 2009.
- [2] E. Scolari, F. Sossan, and M. Paolone, "Photovoltaic-model-based solar irradiance estimators: Performance comparison and application onto maximum power forecasting," *IEEE Trans. Sustain. Energy*, vol. 9, no. 1, pp. 35–44, 2018.
- [3] E. Dirks, A. M. Gole, and T. S. Molinski, "Performance evaluation of a building integrated photovoltaic array using an internet based monitoring system," *2006 IEEE Power Eng. Soc. Gen. Meet. PES*, vol. 4, pp. 4–8, 2006.
- [4] A. A. A. Radwan, Y. A. R. I. Mohamed, and E. F. El-Saadany, "Assessment and performance evaluation of DC-side interactions of voltage-source inverters interfacing renewable energy systems," *Sustain. Energy, Grids Networks*, vol. 1, pp. 28–44, 2015.
- [5] A. R. Bhatti, Z. Salam, and R. H. Ashique, "Electric Vehicle Charging Using Photovoltaic based Microgrid for Remote Islands," *Energy Procedia*, vol. 103, no. April, pp. 213–218, 2016.
- [6] M. Ünlü, S. Çamur, E. Beşer, and B. Arifoğlu, "A current-forced line-commutated inverter for single-phase grid-connected photovoltaic generation systems," *Adv. Electr. Comput. Eng.*, vol. 15, no. 2, pp. 85–92, 2015.
- [7] T. Mori, H. Funato, S. Ogasawara, F. Okazaki, and Y. Hirota, "H-bridge Step-down Converter Applied Proposed Switching Transient Waveform Modification to Reduce Specific Harmonics", *Int. Conf. on Renewable Energy Research and Applications*, 2012.
- [8] R. Adda, S. Mishra, and A. Joshi, "A PWM control strategy for switched boost inverter," *IEEE Energy Convers. Congr. Expo. Energy Convers. Innov. a Clean Energy Futur. ECCE 2011, Proc.*, pp. 991–996, 2011.
- [9] A. Paul, K. Subramanian, and S. Nachinarkiniyan, "PV-based off-board electric vehicle battery charger using BIDC," *Turkish J. Electr. Eng. Comput. Sci.*, vol. 27, no. 4, pp. 2850–2865, 2019.
- [10] Y. Kobayashi, M. Hamanaka, K. Niimi, K. Yukita, T. Matsumura, and Y. Goto, "Power Quality Improvement Method Using EV for PV Output Fluctuation," *6th IEEE Int. Conf. Smart Grid, icSmartGrids 2018*, pp. 272–275, 2019.
- [11] Abdelhakim Belkaid, Ilhami Colak, Korhan Kayisli, and Ramazan Bayindir, "Design and Implementation of a Cuk Converter Controlled by a Direct Duty Cycle INC-MPPT in PV Battery System | Belkaid | International Journal of Smart Grid – Smart Grid," *Int. J. Smart Grid*, vol. 3, no. 1, pp. 19–25, 2019.
- [12] D. Gueye *et al.*, "Design Methodology of Novel PID for Efficient Integration of PV Power to Electrical Distributed Network," *Int. J. Smart Grid*, vol. 2, no. 1, 2018.
- [13] S. Ikeda and F. Kurokawa, "Isolated and Wide Input Ranged Boost Full Bridge DC-DC Converter for Improved Resilience of Renewable Energy System," *6th Int. Conf. Renewable Energy Research and Applications*, vol. 5, pp. 5–10, 2017.
- [14] J. Zhang, S. Member, J. Lai, R. Kim, and S. Member, "High-Power Density Design of a Soft-Switching High-Power Bidirectional dc – dc Converter," *IEEE Trans. Power Electronics*, vol. 22, no. 4, pp. 1145–1153, 2007.
- [15] Y. Zhang and P. C. Sen, "A new soft-switching technique for buck, boost, and buck-boost converters," *IEEE Trans. Ind. Appl.*, vol. 39, no. 6, pp. 1775–1782, 2003.
- [16] P. K. Jain, W. Kang, H. Soin, and Y. Xi, "Analysis and design considerations of a load and line in dependent zero voltage switching full bridge DC/DC converter topology," *IEEE Trans. Power Electronics*, vol. 17, no. 5, pp. 649–657, 2002.
- [17] W. Yu and J. S. Lai, "Ultra high efficiency bidirectional dc-dc converter with multi-frequency pulse width modulation," *Conf. Proc. - IEEE Appl. Power Electronics. Conf. Expo. - APEC*, pp. 1079–1084, 2008.
- [18] J. Zhang, J. S. Lai, and W. Yu, "Bidirectional DC-DC converter modeling and unified controller with digital implementation," *Conf. Proc. - IEEE Appl. Power Electronics. Conf. Expo. - APEC*, vol. 2, pp. 1747–1753, 2008.
- [19] D. Flores Cortez, G. Waltrich, J. Fraigneau, H. Miranda, and I. Barbi, "DC-DC Converter for Dual-Voltage Automotive Systems Based on Bidirectional Hybrid Switched-Capacitor Architectures," *IEEE Trans. Ind. Electronics*, vol. 62, no. 5, pp. 3296–3304, 2015.

- [20] Y. S. Lee, H. W. Huang, and T. H. Chou, "Bidirectional DC-DC converter with multiple switched-capacitor cells," *2014 Int. Power Electron. Conf. IPEC-Hiroshima - ECCE Asia 2014*, no. Ccm, pp.421–428,2014.
- [21] S. Xiong and S. Tan, "Cascaded High-Voltage-Gain Bidirectional Switched-Capacitor DC –DC Converters," *IEEE Trans.Power Electronics*, vol.32,no.2,pp.1220–1231,2017.
- [22] Y.Wang, L.Xue, S. Member, C.Wang, .Member, "Interleaved High-Conversion-Ratio Bidirectional DC–DC Converter for Distributed Energy- Storage Systems—Circuit Generation, Analysis ,and Design, " *IEEE Trans. Power Electronics*, vol.31,no.8,pp.5547–5561,2016.
- [23] R. Ling, G. Zhao, and Q. Huang, "High step-up interleaved boost converter with low switch voltage stress," *Electr. Power Syst. Res.*, vol. 128,no.February,pp.11–18,2015.