

DC SOURCE FED INDUCTION MOTOR DRIVE SYSTEM FOR ELECTRIC VEHICLE APPLICATIONS

Dr. K R Vadivelu, Professor, EEE Department, Ramachandra College of Engineering, Eluru

Dr. S. S. Sarma, Associate Professor, EEE Department, Ramachandra College of Engineering, Eluru

Mrs. G Hari Priya, Assistant Professor, EEE Department, Ramachandra College of Engineering, Eluru

Dr. J. Ranga, Professor, EEE Department, Ramachandra College of Engineering, Eluru

Mr. V N S R Murthy, Assistant Professor, EEE Department, Ramachandra College of Engineering, Eluru

Abstract: In recent years demand for electrical energy is increasing at a rapid pace. In such contrast standalone systems are gaining importance. In a country like India where most of the people are dependent on agriculture sector, water is the prime source of demand. Due to the irregular monsoon seasons and non-availability of water from canals, most of the farmers are dependent on ground water for crop fertility. These further increases demand on grid. To make the grid burden free a standalone system consisting of a boost converter coupled to a multilevel inverter is proposed for running agriculture motor. The proposed system consists of a transformer less DC-DC Converter to obtain larger conversion gain and a 9-level inverter to get AC voltage of power frequency. The main advantage of a transformer less DC-DC converter is high efficiency, less stress over switches, faster transient response, and better reliability. A diode clamped multi-level inverter is used for production 9 level stepped sine wave. The proposed scheme is simulated with the help of MATLAB R2018b and the harmonic analysis is performed for different values of duty ratios of the DC-DC Converter.

INTRODUCTION

Deregulation of the power industry will undoubtedly have a great impact on utilities' competition for customers. Industrial and commercial customers that cannot tolerate variations in their electrical supply likely will request "premium power." It is anticipated that they will want contracts detailing certain tolerances in a utility's voltage magnitude, distortion, and limits on the number of outages per year. Utilities, in turn, will probably put limitations on the power factor, current harmonic distortion, and peak power that the customer can impose on the utility. To meet the objectives detailed in these new premium power agreements, the implementation of advanced power electronic technologies that can simultaneously improve the power quality for both utilities and their customers will be in demand. By connecting two active inverter-based filters with a common dc link, the combined back-to-back converter can be interfaced with the utility system in both a series and parallel

manner. By having these two inverters connected to the electrical system, simultaneous control of the current demanded from the utility and the voltage delivered to the load can be accomplished. This series-parallel active power filter has been referred to as a universal power conditioner when applied to electrical distribution systems, and as a universal power flow controller when applied at the transmission level. Multilevel voltage-source inverters' unique structure allows them to span high voltages and to reduce individual device switching frequency without the use of transformers. The diode-clamped inverter can synthesize a desired wave form from several levels of dc voltages, and all six phases of a back-to-back converter can share the same common dc link. Consequently, the integration of a multilevel diodeclamped inverter into a universal power conditioner is an enticing prospect. For a multilevel universal power conditioner (MUPC) that will perform sag compensation, the majority of its operating mode will likely be in low modulation index operating regions because sags are quite infrequent and for a minimal duration. Because of this, how to maximize level usage in a diode-clamped inverter for low modulation indexes has been previously explored. A novel carrier rotation technique has enabled active device usage to be balanced among a diode-clamped converter's constituent levels during low amplitude modulation index operating conditions. The switching frequency could also be increased in conjunction with this method without exceeding the thermal limits of the active devices. This increased the frequency spectrum and hastened the dynamic response of the inverter, yet did not exceed the allowable switching loss of the active devices. Because of the different compensation objectives of the series inverter and the parallel inverter, two distinct control techniques are adapted for their use. Simulation and experimental results verify that the algorithms developed will enable the back-to-back diode-clamped converter to quickly respond to deviations from established tolerances in the utility's voltage or the customer's current.

With the advent of multilevel inverters, the performances of medium and high voltage drives have changed drastically. As the number of voltage levels increases, the output voltage is closer to sine wave with reduced harmonic content, improving the performance of the drive greatly as presented. One of the pioneering works in the field of multilevel inverters is the neutral point clamped inverter.

On the other hand, the use of multiple isolated DC sources using Hbridges for plasma stabilization generating multiple voltage levels was presented. The work presented on analyzes the issues with the scheme of cascading multiple rectifiers and proposes a solution for balancing the capacitors. The work presented generates multiple voltage levels by switching the load current through capacitors. Here the voltage through the capacitors can be maintained at desired value by changing the direction of load current through the capacitor by choosing the redundant states for the same pole voltage. The work presented combines the concepts of work presented in and. Here, the floating capacitor H-bridge is used to generate multiple output voltages. The voltages of the capacitors are maintained at their intended values by switching through redundant states for the same voltage level. The works presented in address aspects of using cascaded H-bridges and propose various efficient control algorithms. Modular multilevel converters which are very popular in HVDC applications are another genre of multilevel converters which can be used for motor drive applications as presented in the concept of cascading flying capacitor inverter with neutral point clamped inverter is presented in. Similar concept has been made available commercially as ABB ACS 2000. The concept of increasing the number of levels using flying capacitor inverter with cross connected capacitors has been presented. An interesting configuration to generate seventeen voltage levels using multiple capacitors is presented. However, in and, the capacitor voltages cannot be balanced instantaneously. They can be balanced only at the fundamental frequency.

MULTILEVEL INVERTERS

A voltage level of three is considered to be the smallest number in multilevel converter topologies. Due to the bi-directional switches, the multilevel VSC can work in both rectifier and inverter modes. This is why most of the time it is referred to as a converter instead of an inverter in this dissertation. A multilevel converter can switch either its input or output nodes (or both) between multiple (more than two) levels of voltage or current. As the number of levels reaches infinity, the output THD approaches zero. The number of the achievable

voltage levels, however, is limited by voltage-imbalance problems, voltage clamping requirements, circuit layout and packaging constraints complexity of the controller, and, of course, capital and maintenance costs. Three different major multilevel converter structures have been applied in industrial applications: cascaded H-bridges converter with separate dc sources, diode clamped, and flying capacitors. The multilevel inverter structures are the main focus of discussion in this chapter; however, the illustrated structures can be implemented for rectifying operation as well. Although each type of multilevel converters shares the advantages of multilevel voltage source inverters, they may be suitable for specific application due to their structures and drawbacks.

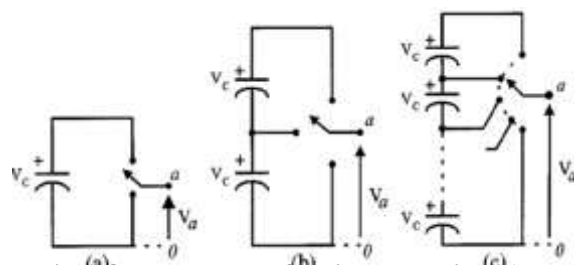

Fig:1 One phase leg of an inverter with (a) two levels, (b) three levels, and (c) n levels

Moreover, multilevel converters present several other advantages:

1. Generate better output waveforms with a lower dv/dt than the standard converters (power Quality).
2. Increase the power quality due to the great number of levels of the output voltage: in this way, the AC side filter can be reduced, decreasing its costs and losses (low switching losses).
3. Can operate with a lower switching frequency than two-level converters, so the Electromagnetic emissions they generate are weaker, making less severe to comply with the standards (EMC).
4. Can be directly connected to high voltage sources without using transformers; this means a reduction of implementation and costs.

Diode-Clamped Multilevel Inverter

The most commonly used multilevel topology is the diode clamped inverter, in which the diode is used as the clamping device to clamp the dc bus voltage so as to achieve steps in the output voltage. The neutral point converter proposed by Nabae, Takahashi, and Akagi in 1981 was essentially a three-level diode-clamped inverter. A three-level diode clamped inverter consists of two pairs of switches and two diodes. Each switch pairs works in complimentary mode and the diodes used to provide access to mid-point voltage. In a three-level inverter each of the three phases of the inverter shares a

common dc bus, which has been subdivided by two capacitors into three levels. The DC bus voltage is split into three voltage levels by using two series connections of DC capacitors, C1 and C2. The voltage stress across each switching device is limited to V_{dc} through the clamping diodes Dc1 and Dc2. It is assumed that the total dc link voltage is V_{dc} and mid-point is regulated at half of the dc link voltage, the voltage across each capacitor is $V_{dc}/2$ ($V_{c1}=V_{c2}=V_{dc}/2$).

Fig:2 Topology of the diode-clamped inverter (a)

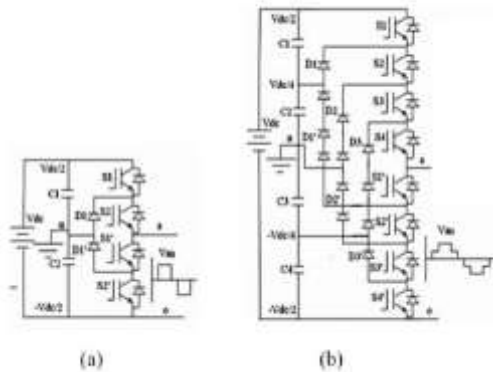

three-level inverter, (b) five - level inverter.

Flying Capacitor Structure

The capacitor clamped inverter alternatively known as flying capacitor was proposed by Meynard and Foch in 1992. The structure of this inverter is similar to that of the diode-clamped inverter except that instead of using clamping diodes, the inverter uses capacitors in their place. The flying capacitor involves series connection of capacitor clamped switching cells. This topology has a ladder structure of dc side capacitors, where the voltage on each capacitor differs from that of the next capacitor. The voltage increment between two adjacent capacitor legs gives the size of the voltage steps in the output waveform. The figure shows the three-level and five-level capacitor clamped inverters respectively.

Fig:3 Capacitor-clamped multilevel inverter circuit

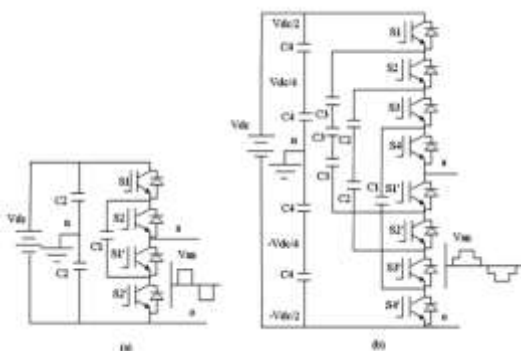

topologies, (a) 3-level inverter (b) 5- level inverter Cascaded Multilevel Inverter

One more alternative for a multilevel inverter is the

cascaded multilevel inverter or series H- ridge inverter. The series H-bridge inverter appeared in 1975. Cascaded multilevel inverter was not fully realized until two researchers, Lai and Peng. They patented it and presented its various advantages in 1997. Since then, the CMI has been utilized in a wide range of applications. With its modularity and flexibility, the CMI 22 shows superiority in high-power applications, especially shunt and series connected FACTS controllers.

The CMI synthesizes its output nearly sinusoidal voltage waveforms by combining many isolated voltage levels. By adding more H-bridge converters, the amount of Var can simply increase without redesign the power stage, and build-in redundancy against individual H-bridge converter failure can be realized. A series of single-phase full bridges makes up

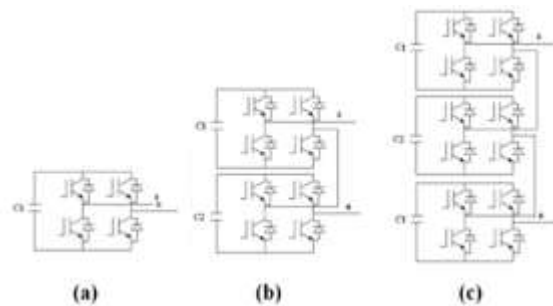

Fig:4 Single phase structures of Cascaded inverter (a) 3-level, (b) 5-level, (c) 7-level

a phase for the inverter. A three-phase CMI topology is essentially composed of three identical phase legs of the series-chain of H-bridge converters, which can possibly generate different output voltage waveforms and offers the potential for AC system phase-balancing. This feature is impossible in other VSC topologies utilizing a common DC link. Since this topology consists of series power conversion cells, the voltage and power level may be easily scaled. The dc link supply for each full bridge converter is provided separately, and this is typically achieved using diode rectifiers fed from isolated secondary windings of a three-phase transformer. Phase-shifted transformers can supply the cells in medium-voltage systems in order to provide high power quality at the utility connection.

Advantages of CMLI are

1. The regulation of the DC buses is simple
2. Modularity of control can be achieved. Unlike the diode clamped and capacitor clamped inverter where the individual phase legs must be modulated by a central controller, the full-bridge inverters of a cascaded structure can be modulated separately.

BLOCK DIAGRAM OF PROPOSED SYSTEM

Block diagram representation of battery based standalone system for control of 3 phase induction motor

is shown in figure 5.

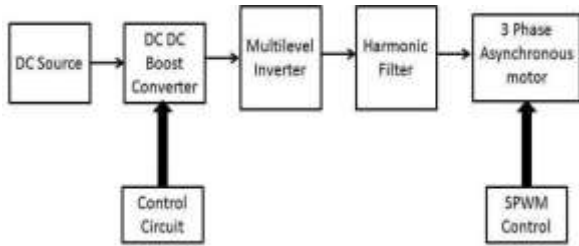

Fig5: Block diagram representation of system proposed for analysis

Description of Components of the system:

DC Source:For the stand-alone system batteries are chosen as primary sources of energy. As the ac voltage that applied across the load terminals is produced with the help a multi-level inverter. A three phase multi-level requires three sources for each of its leg. 6 batteries made of Nickel- Metal-Hydride each of 150AH, 12V capacity are connected in parallel.

DC-DC Boost Converter:The purpose of DC – DC Converter is to provide a stabilized DC Voltage at the input terminals of the inverter. High step up gain can be obtained by using coupled inductor based dc – dc converters. In the proposed circuit a boost converter with a step-up gain ratio 24 is used.

Diode clamped Multi level inverter:A five level diode clamped multi-level inverter is used to obtain a stepped sine wave output. The main advantage multi-level inverters are they produce less distorted sine wave.

Harmonic Filter and Asynchronous machine: A second order harmonic filter with damping ratio 0.9 is used to filter the output voltage of multi-level inverter.

SIMULATION RESULTS

Model proposed with the components described in the block diagram has been constructed and is presented

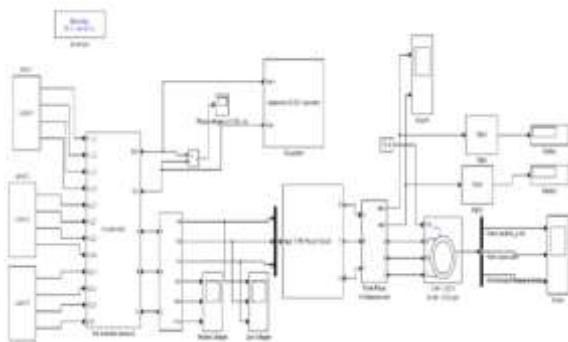
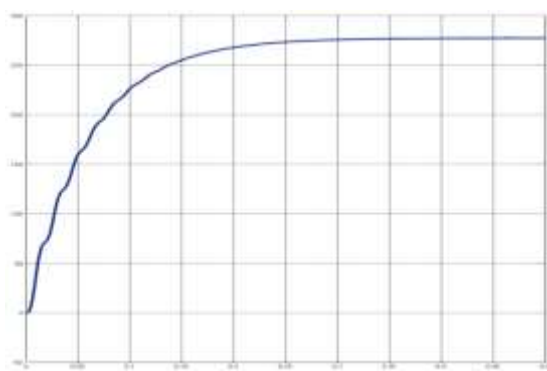

Fig 6: Simulink model of proposed configuration



in fig 6. In the proposed model two high step up gain dc-dc converters are cascaded to increase the dc input voltage applied across the input terminals of inverter.

Fig 7: Output Voltage of DC – DC Converter

Fig 8: Output Voltage of MLI (Phase Voltages)

Fig 9: Output Voltage of MLI with filter (Phase Voltages)

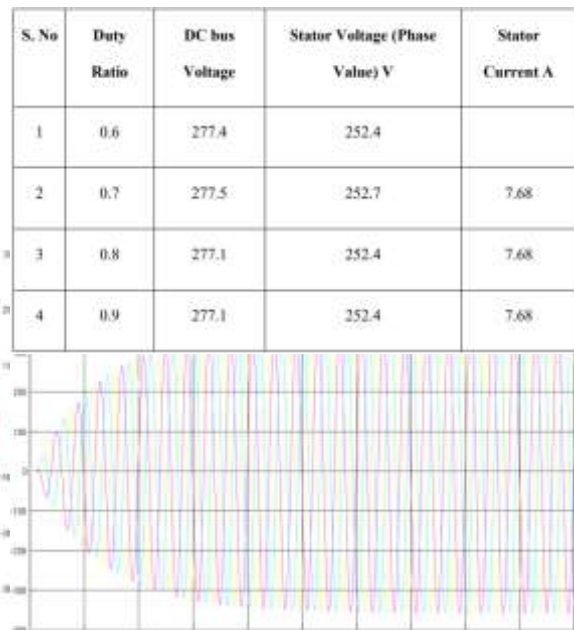

Fig 10: Steady state values of stator current and applied voltages of Induction motor.

PROTOTYPE IMPLEMENTATION

This paper presents solar PV powered Electric Vehicle, that solves the key downside of fuel and pollution. It is an initiative in implementing eco-friendly transportation in the world to build a green environment. In general, an electric vehicle uses a battery that is charged



from an external power supply, but solar PV modules are used to charge a battery by means of absorbing radiation from the sun and converting it into electrical power (Photovoltaic Effect) by proposed method. The electrical power to batteries obtained from solar PV modules which might be associated either in series or parallel and charge controllers.

Technical Specifications used for Solar powered EV

Vehicle weight	130 Kg without battery
Length, Breadth & Height	2060, 1340, 1234 (mm)
Body material	F.R.P.
Chassis Material	Aluminium Alloy & Cast Iron
Average speed	30 Km/hr
Top speed	40 Km/hr
Without sunlight	35 Km
Range in Sun light	< Km
Motor output	100 Watt (200 watt peak power)
Max load capacity	250 Kg
Battery	12 V, 20 AH – 4 Units
Battery complete charging time	4.5 Hrs (approx.) by solar power
Battery charging time by AC current	3 Hrs
Solar panel	100 Watt
Suspension System	Swing Trailing Arm (Front) Swing Arm (Rear)
Steering System	Rack and Pinion Type
Turning Radius	4.5 m.
Brake System	Hydraulic Disc (Front) Hydraulic Disc (Rear) Size: F(200mm) and R(200mm)



Fig 11: Rear view of PV powered EV

Fig 12: Front view of PV powered EV

CONCLUSION

In this paper, a DC source fed diode clamped multilevel inverter with 9 level voltage generation cascaded with high voltage gain based DC – DC converters for

production of 3 phase AC voltages using batteries as source of supply. The proposed scheme can be used as a standalone system connected to the grid or by incorporating the bidirectional features to the dc –dc converter a PV based input systems can be used for charging batteries. During non-monsoon periods water scarcity is a major issue of concern. Such problems can get eliminated using the proposed architecture. Dependency on grid also will be minimized as a result quality power is made available to the consumers.

REFERENCES

[1]. Tsong-JuuLiang,, Shih-Ming Chen, Lung-Sheng Yang, Jiann-Fuh Chen, Adrian Ioinovici, Ultra-Large Gain Step-Up Switched-Capacitor DC-DC Converter With Coupled Inductor for Alternative Sources of Energy, IEEE Transactions On Circuits And Systems— I: Regular Papers, Vol. 59, No. 4, April 2012.

[2]. T.Umeno, K.Takahashi,F.Ueno, T. Inoue, and I. Oota, —A new approach to low ripple-noise switching converters on the basis of switched capacitor converters,|| in Proc. IEEE Int. Symp. Circuits Systems, Jun. 1991, pp. 1077–1080.

[3]. H. Chung and Y. K. Mok, —Development of a switched capacitor DC-DC boost converter with continuous input current waveform,||IEEE Trans. Circuits Syst. I, Fundam. Theory Appl. , vol. 46, no. 6, pp.756–759, Jun. 1999.

[4]. Abutbul, A. Gherlitz, Y. Berkovich, and A. Ioinovici, —Step upswitching-mode converter with high voltage gain using a switched capacitor circuit,|| IEEE Trans. Syst. I, Fundam. Theory Appl. , vol. 50,no. 8, pp. 1098–1102, Aug. 2003.

[5]. S.C.Tan, S.Bronstein, M.Nur, Y.M.Lai, A.Ioinovici, andC.K.Tse,—Variable structure modelling and design of switched-capacitor converters,|| IEEE Trans. Circuits Syst. I, Reg. Papers , vol. 56, no. 9, pp.2132–2142, Sep. 2009.

[6]. T. Chandrasekar, J.Rahila and A.Kannabhiran,|| A grid tied solar panel interfacing using $2(\Sigma 3(N-1))+1$ level inverter with single carrier sinusoidal modulation; where N is the number of H-bridges" International Journal of Electrical Engineering,vol.4,pp. 733-742,2011.

[7]. Y. Li, D. M. Vilathgamuwa, and P. C. Loh, —Design, analysis, and real-time testing of a controller for multi bus micro grid system,|| IEEE Trans. Power Electron., vol. 19, no. 5, pp. 1195–1204, Sep. 2004.

[8]. C. L. Chen, Y. Wang, J. S. Lai, Y. S. Lee, and D. Martin, —Design of parallel inverters for smooth mode transfer micro grid applications,|| IEEE Trans. Power Electron., vol. 25, no. 1, pp. 6–15, Jan. 2010.

- [9]. A. Timbus, M. Liserre, R. Teodorescu, P. Rodriguez, and F. Blaabjerg, —Evaluation of current controllers for distributed power generation systems, *IEEE Trans. Power Electron.*, vol. 24, no. 3, pp. 654–664, Mar. 2009. [10]. Y. A.-R. I. Mohamed and E. F. El Saadany, —Hybrid variable-structure control with evolutionary optimum-tuning algorithm for fast grid-voltage regulation using inverter-based distributed generation, *IEEE Trans. Power Electron.*, vol. 23, no. 3, pp. 1334–1341, May 2008. [11]. Y. A.-R. I. Mohamed and E. F. El Saadany, —Adaptive decentralized droop controller to preserve power sharing stability of paralleled inverters in distributed generation micro grids, *IEEE Trans. Power Electron.*, vol. 23, no. 6, pp. 2806–2816, Nov. 2008. [12]. Y. W. Li and C.-N. Kao, —An accurate power control strategy for power-electronics interfaced distributed generation units operating in a low-voltage multi bus micro grid, *IEEE Trans. Power Electron.*, vol. 24, no. 12, pp. 2977–2988, Dec. 2009. [13]. H. Karimi, A. Yazdani, and R. Iravani, —Negative-sequence current injection for fast islanding detection of a distributed resource unit, *IEEE Trans. Power Electron.*, vol. 23, no. 1, pp. 298–307, Jan. 2008. [14]. T. Shimizu, K. Wada, and N. Nakamura, —Fly back-type single-phase utility interactive inverter with power pulsation decoupling on the dc input for an ac photovoltaic module system, *IEEE Trans. Power Electron.*, vol. 21, no. 5, pp. 1264–1272, Sep. 2006. [15]. A. M. Salamah, S. J. Finney, and B. W. Williams, —Single-phase voltage source inverter with a bidirectional buck–boost stage for harmonic injection and distributed generation, *IEEE Trans. Power Electron.*, vol. 24, no. 2, pp. 376–387, Feb. 2009. [16]. A. Cid-Pastor, L. Martínez-Salamero, C. Alonso, A. El Aroudi, and H. ValderramaBlavi, —Power distribution based on gyrators, *IEEE Trans. Power Electron.*, vol. 24, no. 12, pp. 2907–2909, Dec. 2009. [17]. Q. Zhao and F. C. Lee, —High-efficiency, high step-up dc–dc converters, *IEEE Trans. Power Electron.*, vol. 18, no. 1, pp. 65–73, Jan. 2003. [18]. L. S. Yang, T. J. Liang, and J. F. Chen, —Transformer-less dc–dc converter with high voltage gain, *IEEE Trans. Ind. Electron.*, vol. 56, no. 8, pp. 3144–3152, Aug. 2009. [19]. R. J. Wai, C. Y. Lin, C. Y. Lin, R. Y. Duan, and Y. R. Chang, —High-efficiency power conversion system for kilowatt-level stand-alone generation unit with low input voltage, *IEEE Trans. Ind. Electron.*, vol. 55, no. 10, pp. 3702–3714, Oct. 2008. [20]. J. A. Carr, D. Hotz, J. C. Balda, H. A. Mantooth, A. Ong, and A. Agarwal, —Assessing the impact of SiC MOSFETs on converter interfaces for distributed energy resources, *IEEE Trans. Power Electron.*, vol. 24, no. 1, pp. 260–270, Jan. 2009. [21]. N. P. Papanikolaou and E. C. Tatakis, —Active voltage clamp in fly back converters operating in CCM mode under wide load variation, *IEEE Trans. Ind. Electron.*, vol. 51, no. 3, pp. 632–640, Jun. 2004. [22]. O. Abutbul, A. Gherlitz, Y. Berkovich, and A. Ioinovici, —Step-up switching-mode converter with high voltage gain using a switched-capacitor circuit, *IEEE Trans. Circuits Syst. I, Fundam. Theory Appl.*, vol. 50, no. 8, pp. 1098–1102, Aug. 2003. [23]. B. Axelrod, Y. Berkovich, and A. Ioinovici, —Switched-capacitor/ switched-inductor structures for getting transformer less hybrid dc–dc PWM converters, *IEEE Trans. Circuits Syst. I, Reg. Papers*, vol. 55, no. 2, pp. 687–696, Mar. 2008. [24]. F. L. Luo, —Six self-lift dc–dc converters, voltage lift technique, *IEEE Trans. Ind. Electron.*, vol. 48, no. 6, pp. 1268–1272, Dec. 2001. [25]. F. L. Luo and H. Ye, —Positive output super-lift converters, *IEEE Trans. Power Electron.*, vol. 18, no. 1, pp. 105–113, Jan. 2003.