

Development of a Voice-Based Door Access Control System

Sasmita Pradhan¹, Sasanka Sekhar Dalai²

¹Asst. Professor, Einstein Academy of Technology & Management, Bhubaneswar

²Asst. Professor, Einstein Academy of Technology & Management, Bhubaneswar

ABSTRACT: *The focal point of this study is the design and construction of voice automatic door opening system. Materials used in the development of this system are: an atmega328 microcontroller, a relay switch, a LM7805 voltage regulator, HC-06 bluetooth module and a character LCD module. The deployed method is based on Bluetooth technology which uses an Android App to send voice command to the door that needs to be controlled. Based on this method, the door can be controlled to either open to lock. When a voice command is sent through the App, the Bluetooth module receives the command and passes it to the microcontroller. The microcontroller then compares this command with the predefined commands which are defined in microcontroller Firmware code. If this command matches, then the microcontroller sends a command to operate a relay module that is used in operating the door lock. The device status (lock or unlock) can be seen on the 16×2 LCD display module.*

KEYWORDS – Bluetooth module, Microcontroller, Relay switch, Voice control, Voltage regulator

I. INTRODUCTION

Present-time events around the world accentuates the importance of security to lives and properties. Security is inherent to the protection of human rights, the reduction of poverty and the creation of an enabling environment for development [1].

The concept of security of doors has been broadened beyond the traditional notions of lock and key method to include the use of microcontroller based digital lock for the safety of doors [2]. Physical keys used to unlock doors are susceptible to duplication and can be misplaced by individuals. The conventional smartcard can be lost, duplicated, stolen, forgotten or impersonated with accuracy. Also, the common biometric technologies and other automations that are being applied have limitations. For instance, an individual's finger can be cut off to perform a fingerprint scan, a pin or password can be hacked using various tricks or permutations and one's picture can be used for facial recognition [3-6].

Among the biometrics methods, voice has the high usability characteristics which include the simplicity for the user, feeling of resistance, speed of authentication and a high level of false-rejection rate [7]. It is a physical security that assures the security of a room or building by limiting access to the room or building to specific people and by keeping records of such accesses [8].

Several researchers have in various techniques designed voice control system [9-13]. This method deploys a bluetooth-based technology which uses an Android App to send voice command to the door that needs to be controlled. If this command matches, then microcontroller sends a command to operate a relay module that is used in operating the door lock. The device status (lock or unlock) is displayed on the 16×2 LCD display module.

II. MATERIALS AND METHODS

Components used in the development of this system are; an atmega328 microcontroller, HC-06 bluetooth module, a relay switch, a character LCD module and a LM7805 voltage regulator used to output the specified DC voltage. It converts a DC input voltage of range 7-25 V to a stable +5 V.

The method for this voice control door lock is based on bluetooth technology using Android App to send voice command to the door that needs to be controlled. Based on this method, the door can be controlled to either open or lock.

The complexity of this system is reduced by the microcontroller. Aside from the external mobile phone and the appliance to be controlled, there are five major blocks in the system. These include the power supply, HC-05 bluetooth module, Microcontroller, LCD display unit and the electric lock module. The microcontroller which is the heart of this system manages and takes control of the whole system process. The HC-05 module is used for sending and receiving voice command through an Android App. A 16×2 LCD is used in displaying the

door status and system process while a transistor is used as a switching unit to drive and activate/deactivate the door.

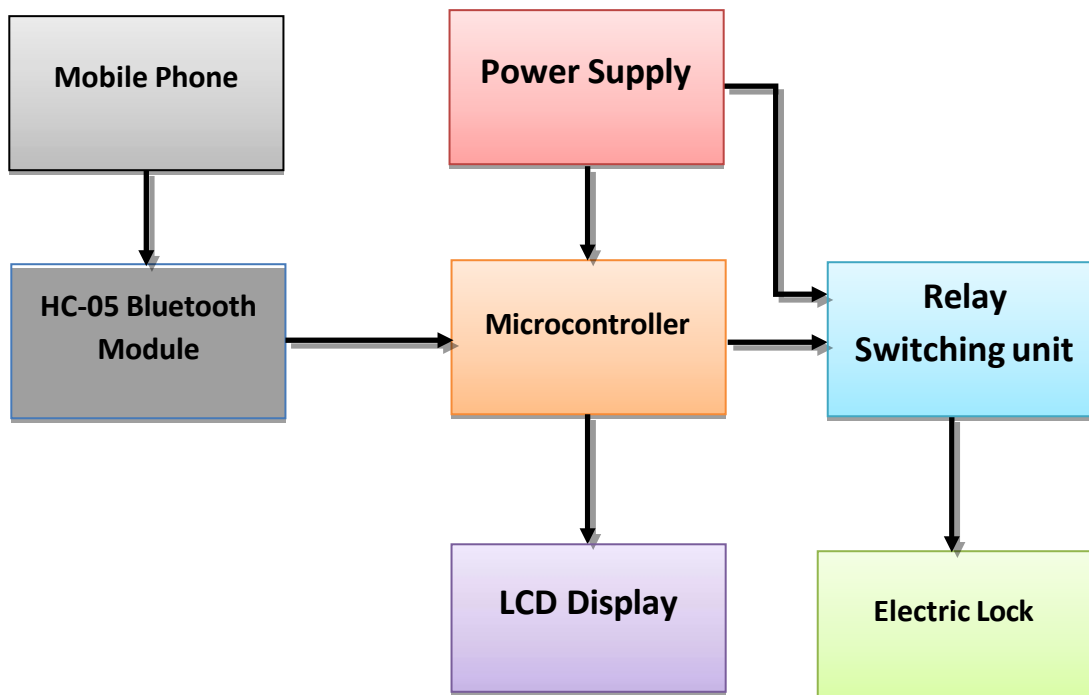

Figure 1: Block Diagram of Voice control door lock

Circuit Description

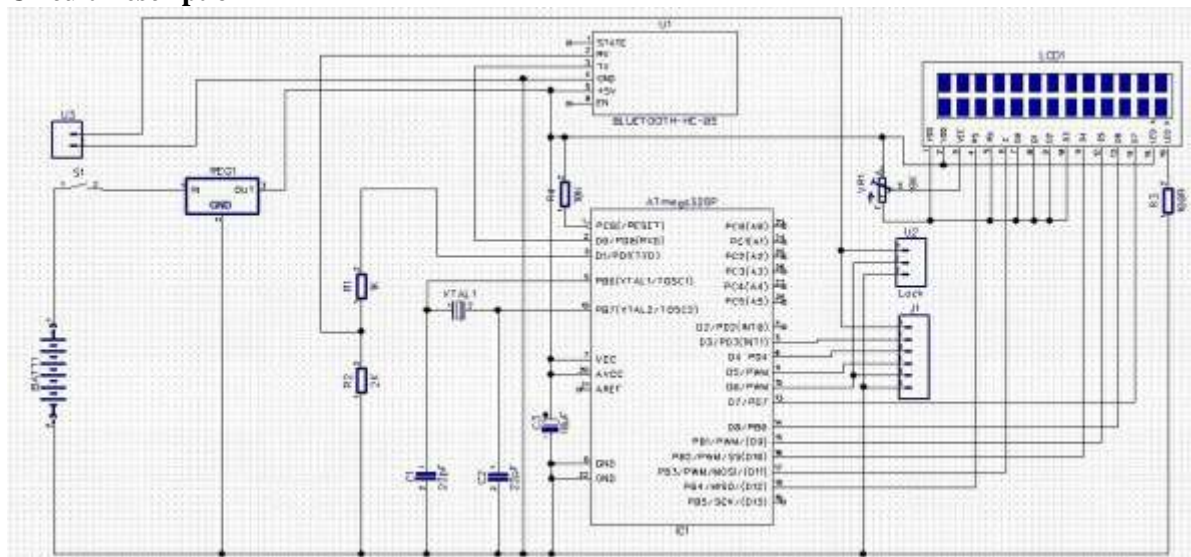

Figure 2: Complete circuit diagram for voice control door lock

The LCD is directly connected to the microcontroller in 4-bit mode. Data pins of LCD namely RS, EN, D4, D5, D6, D7 are connected to microcontroller digital pin number 6, 7, 8, 9, 10, 11. The Rx and Tx pin of HC-05 module is connected to Tx and Rx pin of microcontroller respectively. The lock connects to the microcontroller digital pin D6 using connector U2 for controlling the electric lock. The system is powered by a 1A, 12V small plug pack adapter. The output DC from this adapter is decoupled into 2, three terminal voltage regulator whose function is to regulate and provide +5V DC supply to the microcontroller, HC-05 module and the LCD display module.

Operational Basics

Two voice commands are used to control the device; the “door lock” command is used to lock the door while the “door unlock” command is used to unlock the door. These Voice commands are used in the microcontroller code. When a voice command is sent through the App, the Bluetooth module receives the command and passes it to the microcontroller. The microcontroller then compares this command with the predefined commands (which are defined in microcontroller Firmware). If this command matches, then microcontroller sends a command to operate a relay module that is used in operating the door lock. The device status (lock or unlock) can be seen on the 16×2 LCD display module.

When “door unlock” voice command is sent through the App, the microcontroller gets this command through the bluetooth module, then sends LOW (0) input voltage to the relay module and the relay will turn off. the device (electric lock) will also turn off, which is connected to the relay1 module. At the same time, the “D1 (door) is unlocked” status print on the 16×2 LCD Display Module. When “door lock” voice command is sent through the App. Again, the microcontroller gets this command through the Bluetooth module. This time the microcontroller will send a HIGH (5v) input voltage to the relay module. The relay will turn On. The device (electric lock) will also turn on, which is connected to the relay module. At the same time, the “D1 (door) is lock” status print on the 16×2 LCD Display Module.

Software and Programming

A screen shot of application that was used in the development of the microcontroller firmware code is shown below. Here, Arduino integrated development environment IDE was used in writing the required firmware for the microcontroller. The firmware program allows control command to be sent to the system through the receipt of voice command. The Firmware program was written in C using Arduino IDE.



Figure 3: Arduino integrated development environment

Arduino IDE provides library for bluetooth module and the LCD display and this makes writing, compiling and programing the microcontroller in Arduino easy. In the code, libraries for the bluetooth module and the LCD display were first included. These libraries contain the core initialization functions that enable the system communicate with the various components attached to it. The microcontroller digital pins were initialized and declared as output.

Testing and result

Testing of the project was one of the paramount things that was done before putting it into use. To accomplish this, a digital multimeter was used in testing and troubleshooting the circuit. Before applying power to the circuit, the integrated circuits were first removed from their respective sockets in the circuit. This was done to avoid damage to the integrated circuits, in case there is a short circuit from wrong connection or PCB track during the construction. To ensure that this does not happen, short circuit test was first carried out to

ensure that there was no short circuit between the PCB connections and other components on the board.

After the short circuit test, an open circuit test was carried out to ensure that no components were left unconnected. Finally, voltage test was carried out to ensure that the correct and maximum allowable voltage was passed to the circuit from the internal power supply. This test helps to make sure that the integrated circuits and other circuit components received the correct voltage so that they may not get damaged during operation and testing.

Before installing the microcontroller, it was a good idea to check that the power supply to the microcontroller was correct. To do this, a 9V to 12V DC was connected to the system, and a check for voltage between pin 14 and pin 5 of the microcontroller IC socket was carried out. Pin 14 should be at +5V with respect to pin 5 (GND). With the result of this test, the microcontroller was finally installed in place and the two boards were connected together through their respective connecting cables. Power was reapplied and the RED LEDs lights in the bluetooth module flashes to indicate that the module was trying to establish connection with the mobile phone. A faint click was also observed from the relay as the completed project turns on. Changing the input selection was done using the switches. It was observed that each time a voice command was sent, the relay controlling the electric lock switches on.

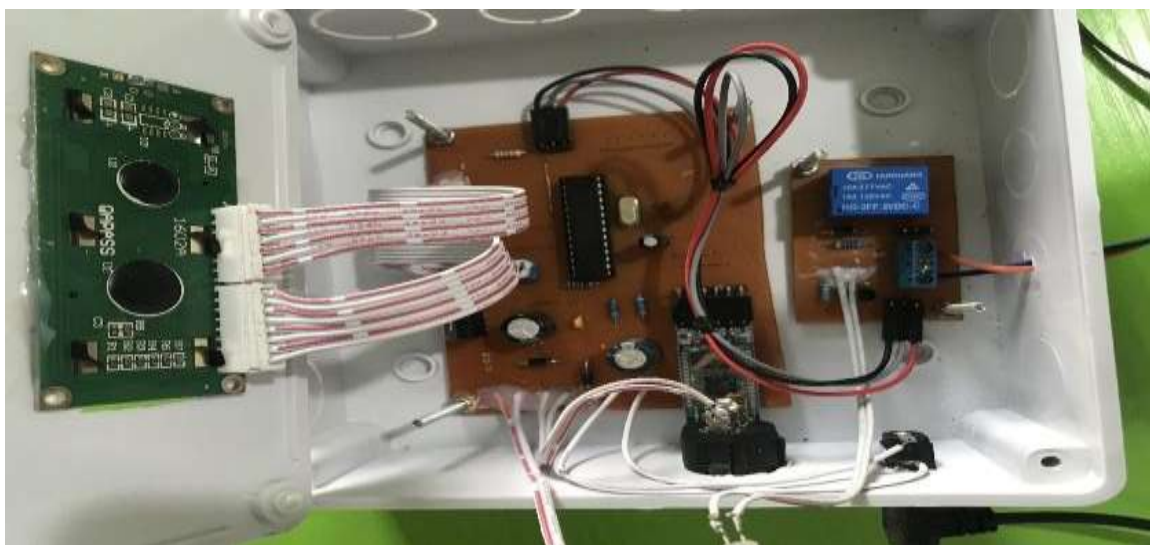

Figure 4: Front view of components inside the box



Figure 5: Front/side view of the system



Figure 6: Side view of switch and adaptor power source



Figure 7: A view of the door status

III. CONCLUSION

This research project provides an insight into voice recognition and door access control systems with the sole aim of securing lives and properties. It is based on bluetooth technology using Android App to send voice command to the door that needs to be controlled. Based on this method, the door can be controlled to either open or Lock. The brain behind the system is an ATmega328 microcontroller which interprets the Bluetooth signal to either open or lock the door.

REFERENCES

- [1]. Organization for Economic Co-Operation and Development (OECD), "Making Poverty Reduction Work", <https://www.oecd.org/development/34839878.pdf>. (Accessed 6th September 2021).
- [2]. M. M. Yilwatda, J. A. Enokela and N. Y. Goshwe, Implementation of a two-level security door access using keypad and voice recognition, *International Journal of Security and its Applications*, 11(4), 2017, 45-58.
- [3]. D. O. Adekola, A. Akinsanya, A. Olufowobi, O. Babajide, O. M. Somefun and A. Oduroye, Voice recognition door access control System, *IOSR Journal of Computer Engineering* 21(5), 2019, 1-12.
- [4]. S. Y. Kung, M.W. Mak and S.H. Lin, 2004. Biometric authentication: a machine learning approach (Englewood NJ: Prentice Hall, 2004).
- [5]. D. D. Zhang, Automated biometrics: technologies and systems (Kluwer Academic Publisher, 2000).

- [6]. L. Osadciw, P. Varshney and K. Veeramachaneni, Improving personal identification accuracy using multisensor fusion for building access control application, In proc. 5th Intl. conf. Information Fusion, Maryland, USA, 2002, 1176- 1183.
- [7]. Hitachi Global, Door-access-control system based on finger-vein authentication. *Hitachi Review*, 53(2), 2004, 79-82
- [8]. W. A. Wahyudi and M. Syazilawati, Intelligent voice-based door access control system using adaptive-network-based fuzzy inference systems (anfis) for building security, *Journal of Computer Science*, 3(5), 2007, 274-280.
- [9]. P. T. Krishna and K. D. Kranti, Voice controlled autonomous wheelchair, proc. of National Conference on Knowledge, Innovation in Technology and Engineering (NCKITE), Raipur, Chhattisgarh, India, 2015, 10-11.
- [10]. HM2007 Speech Recognition, <https://www.imagesco.com/speech/HM2007.pdf>. (Accessed 5th September, 2021).
- [11]. S. T. Dhawan and S. Aditi, Voice recognition wireless home automation system based on zigbee, *IOSR Journal of Electronics and Communication Engineering*, 6(1), 2013, 65-75.
- [12]. A. M. Omar, T. H. Rasha and T. Nicolae, Access control using biometrics features with arduino galileo, *International Journal of Advanced Research in Computer Science and Software Engineering*, 4(8), 2014, 134-140.
- [13]. S. H. K. Yahya, Speaker Independent voice recognition calculator, *Contemporary Engineering Sciences*, 5(3), 2012, 119-125.