

# THE MIST COOLING SYSTEM

Sanjay Mali <sup>(1)</sup>, Debabrata Sethi <sup>(1)</sup>, Raja Sethi <sup>(1)</sup>, Raj Kumar Das <sup>(1)</sup>

Swagatika Acharya <sup>(2)</sup>

<sup>1</sup>UG Scholar, Department of Mechanical Engineering, Gandhi Institute for Technology (GIFT), Bhubaneswar

<sup>2</sup>Asst. Professor, Department of Mechanical Engineering, Gandhi Institute for Technology (GIFT), Bhubaneswar

## ABSTRACT

*A cooling system that sprays micro water droplets could prove useful in mitigating temperature increases in urban areas by using the heat of water evaporation, a process that consumes only small amounts of water and energy. If water mist is sprayed in a semi-outdoor area, for example, under a canopy, it could potentially improve conditions on hot days. However, there is little reference data concerning the design or control of such systems. In order to propose a method for designing and predicting the performance of a water mist system, we discuss differences in cooling effects in the context of particle size distribution of water mist. The results of numerical fluid analysis showed there is no significant difference in temperature reduction for different particle sizes. However, the water particles remained in a lower position with larger particles.*

**Keywords-** Mitigation technologies; natural sinks; passive cooling; heat dissipation

---

## LITERATURE REVIEW

1. Abdalla et al [1] aimed to review the recent developments concerning evaporative cooling technologies that could potentially provide sufficient cooling comfort, reduce environmental impact and lower energy consumption in buildings. Air-conditioning plays an essential role in ensuring occupants thermal comfort. However, building's electricity bills have become unaffordable. Yet the commercially dominant cooling systems are intensively power-consuming ones, i.e. vapor compression systems. An extensive literature review has been conducted and mapped out the state-of-the-art evaporative cooling systems. The review covers direct evaporative cooling, indirect evaporative cooling and combined direct-indirect cooling systems. The indirect evaporative coolers include both wet-bulb temperature evaporative coolers and dew point evaporative coolers have been of particular interest because of high thermal performance. The dew point evaporative coolers have shown great potential of development and research opportunity for their improved efficiency and low energy use.
2. Celata et al [2] used pump for supplying water required to moisten the evaporative cooling surface was eliminated. The system was constructed and tested under varying temperature, relative humidity and air flow rates. Results showed significant temperature reduction accompanied with acceptable increase in relative humidity. Temperature drop of (6-10) °C between the inlet and outlet temperatures of the product or supply air was recorded. Increase in relative humidity of the supply air was (6 –10) % less than the working air.
3. Holman et.al.[3] aims to analyze the influence of some operation parameters, such as the reactivation temperature of the adsorbent, and the relationship between the reactivation air flow and the process air flow (R/P) on the performance of the system. In addition, this paper presents an application of a proposed system in different climate characteristics of several tropical and equatorial cities.
4. Hamlin et.al. [4] carried out experimental device to study thermal performance of the evaporative coolers, their studies concentrate on changing pack thickness. The increase in pack thickness from (5.5cm) to (13cm) leads to effectiveness more than (51%). Also they studied possibility to develop water distribution system and water pump power. The results indicate that the use of these modifications together leads to effectiveness of more than (90 %).
5. Hosoz et al [5] drip evaporative cooling method was constructed with simple materials and used for the preservation of fruits and vegetables. It consists of a simple low cost cavity wall evaporative cooler constructed from bricks and termed as "Improved Zero-Energy Cool Chamber" in India.

## BASIC CONCEPT DESIGN

The air conditioning system is a foremost energy consuming commodity in the domestic and industrial applications to maintain the air temperature and humidity in the space. The building sector is the major

contributor to the energy consumption; it consumes about 50 % of the world energy consumption. In domestic and commercial premises, air conditioning systems consume about 30 % of electricity. Lot of research work is carried out in evaporative cooling techniques such as direct evaporative cooling, indirect evaporative cooling, combined direct and indirect evaporative cooling, different types of cooling media and materials etc in order to improve the energy efficiency and cooling capacity. Hsieh et al. [6,7] have developed a numerical model for direct evaporative cooler having a compact metallic air/water interface to predict the outlet air temperature. The predicted and experimental results are compared and observed with 1.33% maximum error. Mzad et al. [8] have theoretically investigated the exchange of energy and concentration among the air stream and water mist particles and proposed the simplified correlation to find the cooling efficiency. Nakayama et al. [9] have analyzed the effect of performance parameters as frontal air velocity, inlet air temperature and incoming water temperature on the cooling effect produced by the system. An empirical correlation is also developed between the frontal air velocity and the cooling effect produced by the system. Qiang [10] had optimized the factors which are affecting the performance of the cooling process by developing a mathematical model and obtained the results as the saturation efficiency with respect to WBT is 0.9 to 1.0.

### CONSTRUCTIONAL DETAIL

This system works by air evaporation of water droplets. Misting system work so effectively because of sufficient water supply. The reserve water through ¼" nylon/steel lines to brass mist nozzles, producing microscopic droplets of water. The fine mist of water droplets droplets hits the hot air and flash evaporates to cool the surrounding space up to 15degrees. When evaporation occurs, temperature drops. The outdoor heat, necessary to cause evaporation, actually draws from the air temperature and cools the surrounding area within seconds. Our misting system do this by atomizing high-pressure water via specialized misting nozzles that produce a fine mist/fog that is perfectly sized for evaporation. The lower the relative humidity, the better the evaporative cooling effect. This system works by air evaporation of water droplets.

#### Diagram of a Simple Pick and Place Robot:

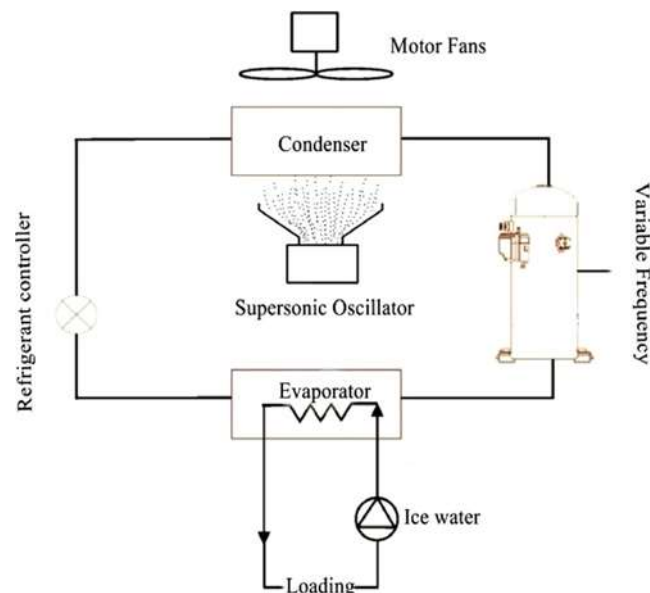

Fig.1 Flow chat of water-cooled chiller components

A variable frequency control was employed to eliminate the frequent starting and stopping of the compressor. It is capable of controlling the temperature, as well as providing a power saving operation and allowing the supersonic atomizer system to adjust the volume of atomization in coordination with the compressor loading status. Because supersonic atomization has mostly been used in the cooling of electronic ships and small

components, and the literature has shown that atomization is capable of carrying away a large amount of heat through the vaporization of water mist, this study was intended to design an experiment platform to measure the data and compare the atomization efficiency with that of traditional air-cooled water chillers.

The design of the supersonic vaporization chiller is shown in Fig. 2(a) and a photograph of its implementation is shown in Fig. 2(b). Fig. 2(a) also shows the experiment platform of the air-cooled water chiller. Its components are (1) a fan; (2) a condenser; (3) a water-mist spray outlet; (4) a Man-machine interface/circuitry assembly; (5) a Refrigerant controller; (6) supersonic atomizer; and (7) a compressor.

Their main functions are as follows:

- ❖ Fan: driving water mist to distribute it evenly over the condenser surface.
- ❖ Condenser: exchanging heat with air (heat dissipation), using the air to carry heat away from the refrigerant inside the condenser so that the high-temperature and high-pressure gaseous refrigerant transforms into a hyper-cooled high-pressure liquid refrigerant of normal temperature.
- ❖ Water-mist spray outlet: outputting required mist for cooling and with a function of preventing from mist leaked out of the effective heat-exchangeable area of condenser.
- ❖ Man-machine interface/circuitry assembly: viewing the status of machine operation, including chilled water temperature, condenser temperature, and operation load.
- ❖ Refrigerant controller: regulating the flow rate of refrigerant entering the evaporator, so that the quantity of liquid refrigerant entering the evaporator equals the quantity of vaporized refrigerant in the evaporator. Another function is to maintain the system pressure difference between the high-pressure side and low-pressure side, to provide the low-pressure required in the evaporator and the high-pressure required in the condenser. The unit uses a capillary as the controller

## **WORKING OF MACHINE**

- ❖ Supersonic atomizer: water is atomized into mist through supersonic vibration and spreads in the air. This apparatus includes a set of supersonic transducers and controllers, via tuning the alternating voltage of relatively high frequency, which can effectively adjust the volume of mist. This was the basic cooling setup of the study.
- ❖ Compressor: The system uses a volute-type compressor, mainly for compressing the refrigerant to generate the high-pressure and low-pressure necessary for the refrigeration cycle. The low-pressure and low temperature gaseous refrigerant is compressed to form high-pressure and hyper-heated refrigerant vapor, which is delivered into the condenser to perform heat-exchange.
- ❖ Evaporator: performing heat exchange of the refrigerant and the water chiller system. Evaporators commonly used in water chillers are the dry expansion type and flooded type. Structurally, heat-exchangers can be categorically divided into shell, pipe, and plate types. This unit uses a plate heat exchanger.

A rapid water flow occurs when a vibrator produces a supersonic wave in water. The liquid at the surface exerts a supersonic beam focusing effect, and forms a supersonic fountain. Because of the rapid water flow, the pressure of the liquid temporarily decreases, forming small bubbles. Internal pressure is considerably low, pulling liquid fission and forming hollowing. When the water pressure is restored, the bubbles move inward and fission collapses. A considerably small blast occurs, but the effect is a considerably large shockwave. The force from the moment of impact causes the liquid to diverge into particles and form a mist. The latent heat required to evaporate a kilogram of water (2430.5 kJ at 30 °C) is equal to the heat required to melt 7 kg of ice. The high pressure sprays droplet sizes of 15–40 μm; the supersonic produces a micro mist diameter in the range of 3–5 μm. The larger the surface area in contact with air, the greater the cooling effect.

To prevent the program from malfunctioning, a protection mechanism is required. The mechanism presented in Fig. 3 can identify any problems at the start of the program. If this occurs, the program does not load the machine's operating status and the fan's current protection compressor, supersonic vibrations, ice water pump, and fan motor shut down. If the program encounters an AI 2 < low pressure setting, the supersonic atomizer turns off, as does the fan motor after a time delay. In this study, ambient air was drawn or blown through a porous wetted surface where the air stream is cooled by water mist, and its dry bulb temperature drops to approach its wet bulb temperature. Where, DO-1 to DO- 4 represents the control switches of compressor, ice water pump.



Fig.2 Supersonic vaporization chiller system

Fig. 3 is a diagram of the closed-loop system. Its main controls are a supersonic oscillation driving circuit (SOD), a pulse-width modulation (PWM) control circuit, and a dual-effect fuzzy control (DEFC). The main functions of the controls are as follows:

1. SOD: producing the frequency of the supersonic atomizer.
2. PWM: adjusting the volume of water misting by controlling the frequency of the supersonic vibrator.
3. DEFC: determining the size of the PWM control signal.

The dual-effect fuzzy control system is used to cover the entire system. The atomization volume output control used the PWM to adjust the supersonic frequency in response to actual demand.

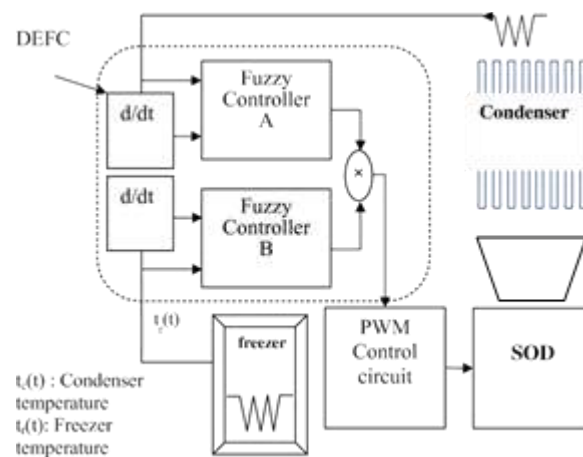

Fig.3 Closed loop system

## **COP calculation**

In this study, the chiller COP was calculated from the measured variables but directly measured. First, the chiller load  $E_L$  can be obtained by (1), then the chiller COP, using the chiller load divided by the measured variables, including the chiller power and supersonic atomizer power. Besides, chiller power includes the compressor power and condenser fan power, can be found and shown in (2).

$$E_L = m_w \cdot C_p (T_{chwr} - T_{chws}) \quad (1)$$

$$COP = E_L / (E_{ch} + E_{sa}) = m_w \cdot C_{WP} (T_{chwr} - T_{chws}) / (E_{cc} + E_{cf} + E_{sa}) \quad (2)$$

where,  $m_w$  is chilled water flow rate ( $m^3/s$ ),  $C_{WP}$  is the specific heat capacity of water ( $4186 J/kg \text{ }^\circ C$ ),  $T_{chws}$  and  $T_{chwr}$  are temperatures of supply and return chilled water ( $^\circ C$ ),  $E_{ch}$  is chiller power (kW),  $E_{sa}$  is supersonic atomizer power (kW),  $E_{cc}$  is compressor power (kW), and  $E_{cf}$  is condenser fan power (kW).

## **Results and discussion**

### **Experimental conditions**

Based on head pressure control, the air-cooled chiller is operated and studied. In order to examine the performance of the air-cooled chiller with or without water-mist cooling system, experiments under a representative range of ambient temperature ( $T_{db}$ : 22.8–36.5  $^\circ C$ ), relative humidity (RH: 33.4%–91.1%) and part load ratios (PLRs: 0.1–1.2) in the local climate of Tainan, Taiwan were conducted over a period of 3 months from July to September 2014.

### **Results**

The temperature distribution was observed using an infrared photo-detector after the air-cooled water chiller was run for 2 h. The condenser temperature was approximately 45.6  $^\circ C$  without supersonic atomization, as displayed in Fig. 5(a). The condenser temperature was approximately 40.2  $^\circ C$  with supersonic atomization, as displayed in Fig. 5(b). The difference was approximately 5.4  $^\circ C$ . The experiment indicated that the studied fixed-frequency air-cooled water chiller consumes 4.249 kW on average, whereas the chiller, equipped with a variable-frequency mist-cooled system, consumes 3.716 kW on average. In addition, through (6) and (7) and using the experimental variables which were measured and logged in every 20-min intervals over the experimental period, the COP values of with/without water-mist cooling system were found. Here, as the studied chiller with mist-cooled system a COP value of 4.34 was obtained. Concluding above results knows that the variable-frequency air-cooled water chiller was 25% more energy efficient.

## **CONCLUSION**

The green industry is becoming increasingly mainstream and people are searching for methods that save power, are energy efficient, and do not pollute the environment. This study established an experimental platform for conducting tests, observing cooling efficiencies, and calculating power saving statuses. Regarding the application's cooling efficiency, a temperature difference of 5.4  $^\circ C$  was observed before and after the application, which is substantial regarding efficiency caused no environmental pollution or water accumulation in its surroundings. When compared with fixed frequency air-cooled water chillers, a 25% energy saving was observed, which is exceptional regarding power saving. The newly developed supersonic mist-cooled water chiller is an effective solution to the problem of rising water and electricity fees.

## **REFERENCES**

1. Abdalla, Abdelhafeez M., Narendran, R., 1991. Fog emitters as evaporative cooling Devices for dairy cow sheds. *Agric. Mech. Asia, Africa and Latin America* 22 (1), 73–76.
2. Celata, G.P., Cumo, M., Mariani, A., 2009. A comparison between spray cooling and film flow cooling during the rewetting of a hot surface. *Heat Mass Transf.* 45, 1029–1035.

3. Ghodbane, M., Holman, J.P., 1991. Experimental study of spray cooling with Freon113. *Int. J. Heat Mass Transfer* 34, 1163–1174.
4. Hamlin, S., Hunt, R., Tassou, S.A., 1998. Enhancing the performance of evaporative spray cooling in air cycle refrigeration and air-conditioning technology. *Appl. Therm. Eng.* 18 (11), 1139–1148.
5. Hosoz1, M., Kilicarslan, A., 2004. Performance evaluations of refrigeration systems with air-cooled, water-cooled and evaporative condensers. *Int. J. Energy Res.* 28 (8), 683–696
6. Hsieh, S.S, Fan, T.C., Tsai, H.H., 2004. Spray cooling characteristics of water and R-134a. Part?: transient cooling. *Int. J. Heat Mass Transfer* 47 (26), 5713–5724
7. Hsieh, S.-S., Tien, C.H., 2006. R-134a spray dynamics and impingement cooling in the non-boiling regime. *Int. J. Heat Mass Transfer* 50, 502–512.
8. Mzad, H., Tebbal, M., 2009. Thermal diagnostics of highly heated surface using water-spray cooling. *Heat Mass Transf.* 45, 287–295.
9. Nakayama, W., Kuwahara, H., Hirasawa, S., 1988. Heat transfer from tube banks to air/water mist flow. *Int. J. Heat Mass Transfer* 31 (2), 449–460.
10. Qiang, C.S.C., Susan, M., 2003. The effect of dissolving salts in water sprays used for quenching a hot surface: part 1-boiling of 59 single droplets. *ASME, J. Heat Transfer* 125, 326–332