

## **Iot Based Air Pollution Monitoring System Using Arduino**

**Chandra Mohan , Ashutosh Kumar Singh , Ashish Kumar Singh**

Department of Electronics and Communication Engineering, Gandhi Institute For Technolgy College, Bhubaneswar. (Affiliated to All India Council for Technical Education (AICTE))

**Durga Prasad Mishra**, Assistant Professor, Department of Electronics and Communication Engineering, Gandhi Institute For Technology College, Bhubaneswar. (Affiliated to All India Council for Technical Education (AICTE))

**ABSTRACT** – The level of pollution has increased with times by lot of factors like the increase in population, increased vehicle use, industrialization and urbanization which results in harmful effects on human wellbeing by directly affecting health of population exposed to it. In order to monitor In this project we are going to make an IOT Based Air Pollution Monitoring System in which we will monitor the Air Quality over a web server using internet and will trigger a alarm when the air quality goes down beyond a certain level, means when there are sufficient amount of harmful gases are present in the air like CO<sub>2</sub>, smoke, alcohol, benzene and NH<sub>3</sub>. It will show the air quality in PPM on the LCD and as well as on webpage so that we can monitor it very easily. In this IOT project, you can monitor the pollution level from anywhere using your computer or mobile.

**Key Words:** Internet of things, air pollution, sound pollution, sensors, monitoring system,arduino

### **INTRODUCTION**

The main objective of IOT Air & Sound Monitoring System is that the Air and sound pollution is a growing issue these days. It is necessary to monitor air quality and keep it under control for a better future and healthy living for all. Due to flexibility and low cost Internet of things (IoT) is getting popular day by day. With the urbanization and with the increase in the vehicles on road the atmospheric conditions have considerably affected. Harmful effects of pollution include mild allergic reactions such as irritation of the throat, eyes and nose as well as some serious problems like bronchitis, heart diseases, pneumonia, lung and aggravated asthma. Monitoring gives measurements of air pollutant and sound pollution concentrations, which can then be analyzed interpreted and presented. This information can then be applicable in many ways. Analysis of monitoring data allows us to assess how bad air pollution and sound pollution is from day to day.

### **EXISTING MODEL**

The commercial meters available in the market are Fluke CO- 220 carbon monoxide meter for CO, Amprobe CO<sub>2</sub> meter for CO<sub>2</sub>, ForbixSemicon LPG gas leakage sensor alarm for LPG leakage detection. The researchers in this field have proposed various air quality monitoring systems based on WSN, GSM and GIS. Now each technology has limited uses according to the intended function, as Zigbee is meant for users with Zigbee trans-receiver, Bluetooth. GIS based system is designed, implemented and tested to monitor the pinpoints of air pollution of any area. It consists of a microcontroller, gas sensors, mobile unit, a temporary memory buffer and a web server with internet connectivity which collects data from different locations along with coordinate's information at certain time of a day. The readings for particular location are averaged in a closed time and space. The Global Positioning System (GPS) module is attached to a system to provide accurate representation of pollution sources in an area. The recorded data is periodically transferred to a computer through a General Packet Radio Service (GPRS) connection and then the data will be displayed on the dedicated website with user acceptance.

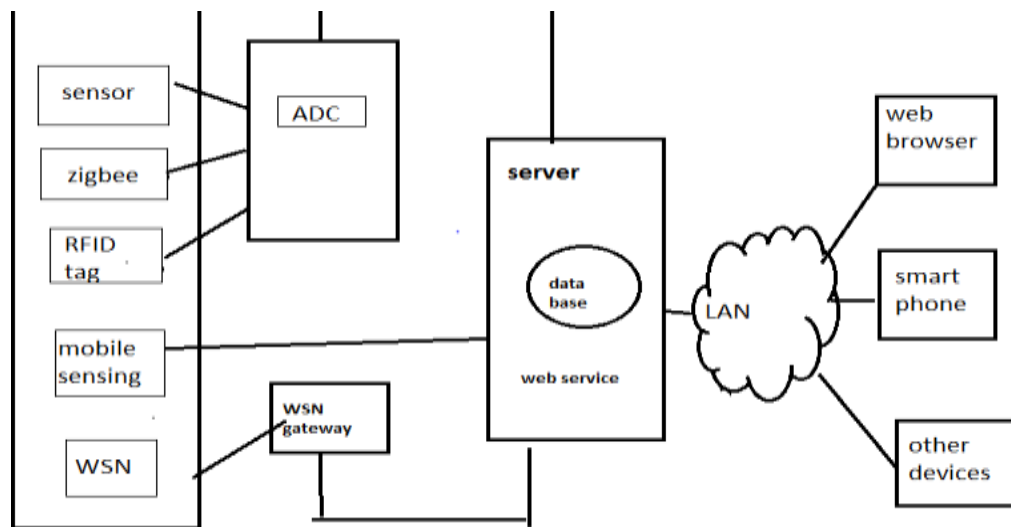

## WHY THIS PROJECT?

We propose an air quality as well as sound pollution monitoring system that allows us to monitor and check live air quality as well as sound pollution in an area through IOT. System uses air sensors to sense presence of harmful gases/compounds in the air and constantly transmit this data. Also, system keeps measuring sound level and reports it. The sensors interact with arduino uno which processes this data and transmits it over the application. This allows authorities to monitor air pollution in different areas and act against it. Also, authorities can keep a watch on the noise pollution near schools, hospitals and no honking areas.

## IOT

The Internet of Things (IoT) is a system of interrelated computing devices, mechanical and digital machines, objects, animals or people that are provided with unique identifiers and the ability to transfer data over a network without requiring human-to-human or human-to-computer interaction. IoT has evolved from the convergence of wireless technologies, micro-electro mechanical systems (MEMS), micro services and the internet. The convergence has helped tear down the silo walls between operational technology (OT) and information technology (IT), allowing unstructured machine-generated data to be analyzed for insights that will drive improvements.

## ARDUINO

Arduino is an open-source electronics platform based on easy-to-use hardware and software. Arduino boards are able to read inputs - light on a sensor, a finger on a button, or a Twitter message - and turn it into an output - activating a motor, turning on an LED, publishing something online. All Arduino boards are completely open-source, empowering users to build them independently and eventually adapt them to their particular needs. The software, too, is open-source, and it is growing through the contributions of users worldwide.

## AIR QUALITY PARAMETERS

The important parameters that are considered in the proposed framework include:

Carbon Dioxide (CO<sub>2</sub>) – CO<sub>2</sub> is colorless, odorless gas and non-combustible gas. Moreover, it is considered under the category of asphyxiate gases that have capability of interfering the availability of oxygen for tissues. Carbon Dioxide is a gas essential to life in the planet, because it is one of the most important elements evolving photosynthesis process, which converts solar into chemical energy. The concentration of CO<sub>2</sub> has increased due mainly to massive fossil fuels burning. This increase makes plants grow rapidly. The rapid growth of undesirable plants leads to the increase use of chemicals to eliminate them.

Sulphur Dioxide (SO<sub>2</sub>) - Sulphur Dioxide is a colorless gas, detectable by the distinct odour and taste. Like

CO<sub>2</sub>, it is mainly due to fossil fuels burning and to industrial processes. In high concentrations may cause respiratory problems, especially in sensitive groups, like asthmatics. It contributes to acid rains.

Nitrogen Dioxide (NO<sub>2</sub>) – Nitrogen Dioxide is a brownish gas, easily detectable for its odour, very corrosive and highly oxidant. It is produced as the result of fossil fuels burning. Usually NO thrown to the atmosphere is converted in NO<sub>2</sub> by chemical processes. In high concentrations, NO<sub>2</sub> may lead to respiratory problems. Like SO<sub>2</sub>, it contributes to acid rains.

Smoke-About 1 million people are in habit of tobacco smoking globally of which majority population is from developing countries. Every year nearly 4.9 million people died due to smoking according to 2007 report. In addition, second hand smoke is serious threat to the health of people of all age's causes 41000 deaths each year.

LPG-Liquefied petroleum gas (LPG) is an odorless and colorless liquid which evaporates readily into a gas. Leakage is normally detected by adding an odorant into it. It is considered under the category of highly flammable gases and it can be classified as a carcinogen and mutagen if Butadiene content is more than 0.1%. LPG may leak in the form of a gas or a liquid. If it leaks in the form of a liquid it evaporates quickly and will eventually form large cloud of gas in air which is relatively heavier than air thus drops to the ground. Whereas, LPG vapors travel along the ground for a long distance and gets collected in drains or basements. Gas leads to burn or explode after getting in touch with a source of ignition.

Temperature and humidity- Measurement of temperature is important for safety of people and affects our life skills. Greenhouse effect can be monitored by measuring temperature and comparing temperature changes from historical to present time especially since the industrial revolution using climate data. Humidity is a type of gas that protects us from UV rays from the sun and helps trap heat on Earth, thereby making the climate on Earth, a pleasant one for living. But as humidity increases, the warmth on Earth also increases which makes our life uncomfortable. Humidity is essential for various storage and food processing facilities.

## **AIR POLLUTION MONITORING EQUIPMENT**

The different components of the equipment along with their intended purpose are discussed below:

### **Arduino Uno R3 microcontroller**

It is the most flexible hardware platform used based on ATmega328P which can be programmed according to the function where it is to be used. It has 6 analog inputs, 14 digital input/output pins (6 pins of these can be used as PWM outputs), a USB Connection, a 16 MHz quartz crystal, SPI, serial interface, a reset button, a power jack and an ICSP header as shown in Fig.3. The Arduino microcontroller is not only for technical audience but is intended for designers and artists as well because of its focus to usability based on its design which helps to achieve the intended goal [6]. It is the primary component of the framework. In addition, it is an open source microcontroller device with easily accessible software/hardware Platform and is compatible with many sensors available. Everything needed for its working is present on the board; we only require a USB cable to directly connect it to the computer or give power using battery source or AC to DC adapter to get started.

### **ESP8266 Wi-Fi Module**

The ESP8266 Wi-Fi Module is a self contained SOC with integrated IP protocol stack that can give any microcontroller access to your Wi-Fi network. Wi-Fi module is capable of either hosting an application or offloading all Wi-Fi networking functions from another application processor. Every ESP8266 module comes pre-programmed with an AT command set firmware, meaning, we can simply connect to the Arduino device. The ESP8266 module is an extremely cost effective board.

### **MQ135 Gas Sensor**

The Sensitive material used in MQ135 gas sensor is SnO<sub>2</sub>. The conductivity of this material is lower in clean air. The sensor conductivity increases with the increasing concentration of target pollution gas. MQ135 can monitor different kinds of toxic gases such as sulphide, ammonia gas, benzene series steam and CO<sub>2</sub>. The detection range is 10- 10,000 ppm with the voltage rate of about 5.0V±0.1V AC or DC.

## **COMPONENTS NEEDED**

MQ135 Gas sensor  
Arduino Uno  
Wi-Fi module ESP8266  
16X2 LCD  
Breadboard  
1K ohm resistors  
220 ohm resistor  
Buzzer

## **CIRCUIT DIAGRAM**

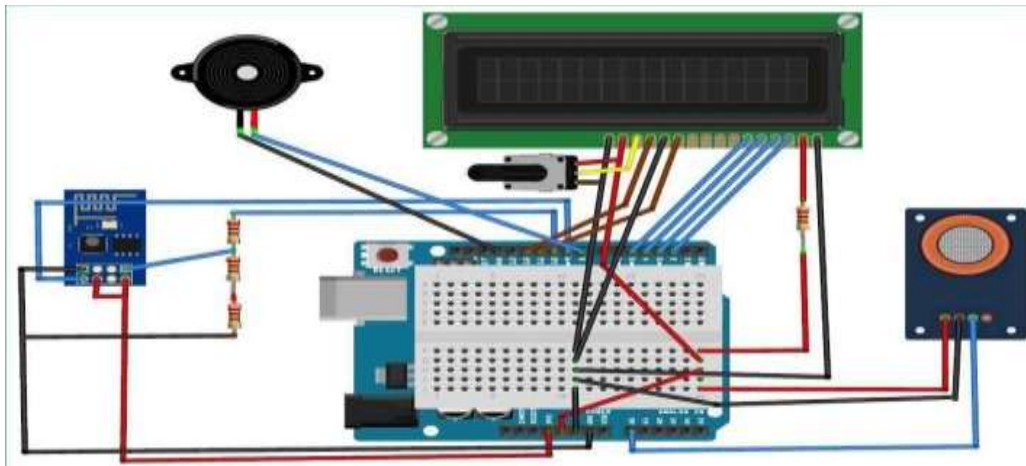

## **WORKING**

We start with connecting the ESP8266 with the Arduino. ESP8266 runs on 3.3V and if you will give it 5V from the Arduino then it won't work properly and it may get damage. Connect the VCC and the CH\_PD to the 3.3V pin of Arduino. The RX pin of ESP8266 works on 3.3V and it will not communicate with the Arduino when we will connect it directly to the Arduino. So, we will have to make a voltage divider for it which will convert the 5V into 3.3V. This can be done by connecting three resistors in series like we did in the circuit. Connect the TX pin of the ESP8266 to the pin 10 of the Arduino and the RX pin of the esp8266 to the pin 9 of Arduino through the resistors.

ESP8266 Wi-Fi module gives your projects access to Wi-Fi or internet. It is a very cheap device and makes your projects very powerful. It can communicate with any microcontroller and it is the most leading devices in the IOT platform. Learn more about here. Then we will connect the MQ135 sensor with the Arduino. Connect the VCC and the ground pin of the sensor to the 5V and ground of the Arduino and the Analog pin of sensor to the A0 of the Arduino. Connect a buzzer to the pin 8 of the Arduino which will start to beep when the condition becomes true. The MQ135 sensor can sense NH<sub>3</sub>, NO<sub>x</sub>, alcohol, Benzene, smoke, CO<sub>2</sub> and some other gases, so it is perfect gas sensor for our Air Quality Monitoring Project. When we will connect it to Arduino then it will sense the gases, and we will get the Pollution level in PPM (parts per million). MQ135 gas sensor gives the output in form of voltage levels and we need to convert it into PPM. So for converting the output in PPM, here we have used a library for MQ135 sensor, it is explained in detail in "Code Explanation" section below. Sensor was giving us value of 90 when there was no gas near it and the safe level of air quality is 350 PPM and it should not exceed 1000 PPM.

## **CONCLUSION**

The system to monitor the air of environment using Arduino microcontroller, IOT Technology is proposed to

improve quality of air. With the use of IOT technology enhances the process of monitoring various aspects of environment such as air quality monitoring issue proposed in this paper. Here the using of MQ135 gas sensor gives the sense of different type of dangerous gas and arduino is the heart of this project which controls the entire process. Wi-Fi module connects the whole process to internet and LCD is used for the visual Output. The Automatic Air & Sound management system is a step forward to contribute a solution to the biggest threat. The air & sound monitoring system overcomes the problem of the highly-polluted areas which is a major issue. It supports the new technology and effectively supports the healthy life concept. This system has features for the people to monitor the amount of pollution on their mobile phones using the application.

## **REFERENCES**

- [1]<https://www.tinkercad.com/>
- [2]<https://circuits.io/>
- [3]<https://www.arduino.cc/>
- [4]<https://circuitdigest.com/microcontroller-projects/iot-air-pollution-monitoring-using-arduino>
- [5]Riteeka Nayak, Malaya Ranjan Panigrahy , Vivek Kumar Rai and T Appa Rao:IOT based air pollution monitoring system Vol-3, Issue-4, 2017
- [6]Navreetinder Kaur , Rita Mahajan and Deepak Bagai: Air Quality Monitoring System based on Arduino Microcontroller Vol. 5, Issue 6, June 2016
- [7]Palaghat Yaswanth Sai: An IoT Based Automated Noise and Air Pollution Monitoring System Vol. 6, Issue 3, March 2017 L.Ezhilarasi, 2 K.Sripriya, 3 A .Suganya , 4 K.Vinodhini
- [8]A System for Monitoring Air and Sound Pollution using Arduino Controller with IOT Technology Vol. 3 Issue 2 (2017) Pages 1781 – 1785
- [9]Exploring Arduino : Tools and Techniques forEngineering Wizardry by Jeremy Blum 1<sup>st</sup> edition
- [10]Ms. Sarika Deshmukh, Mr.Saurabh surendran and Prof.M.P. Sardey:Air and Sound Pollution Monitoring System using IoT Volume: 5 Issue: 6