

Automatic Door Opening And Closing

Indradev Kumar, Rohit Pradhan, Nilamadhab Pattnaik, Bablu Kumar

Department of Electronics and Communication Engineering, Gandhi Institute For Technolgy College, Bhubaneswar. (Affiliated to All India Council for Technical Education (AICTE))

Jharana Behera, Assistant Professor, Department of Electronics and Communication Engineering, Gandhi Institute For Technology College, Bhubaneswar. (Affiliated to All India Council for Technical Education (AICTE))

ABSTRACT

In the current pandemic situation is arising due to COVID -19, So every human has required to take precaution like wear mass, keep distancing, sanitizing hand, don't touch anything if not necessary. But something is like Table, door, vehicles etc. we touch so there is chance of spreading disease. So,we have suggested idea for prevent them, the project is based on automation, in which we will making an automatic opening and closing of door mechanism (home/college swinging door). In which the door is open when the Ultrasonic sensor on the door cut then mechanism is operated and open the door and after close automatically. So, there is no physical touch of human with door, hence it will help to prevent or reduce the spreading of pandemic disease COVID-19. Our project is based on Ultrasonic Sensor and Arduino, in which door is automatically opens and closes by detecting a person.

Key Words - COVID-19, Swinging Door, Ultrasonic Sensor, and Stepper Motor, Swinging Door, Arduino, And Motor Driver.

INTRODUCTION

In the current pandemic situation is arisen due to COVID -19, So every human has required to take precaution like wear mask, keep distancing, sanitizing hand, don't touch anything if not necessary. But something is like Table, door, vehicles etc. we touch so there is chance of spreading disease. In college and Offices, the peoples are meet so there are chances spreading disease due to the touching of door or any other thing on which germs are present. The project is based on automation, in which we will making an automatic opening and closing of door mechanism (home/college door). In which the door is open when the sensor on the door cut then mechanism is operated and open the door and after close automatically. So, there is no physical touch of human with door, hence it will help to prevent or reduce the spreading of pandemic disease COVID-19.

Our project is based on Ultrasonic Sensor and Arduino, in which door is automatically opens and closes by detecting a person. As soon as a person approaches the door (at about 2 or 3 feet), the door automatically turned open and after some time (about 5 to 10 seconds), the door closes by turning in the reverse direction. Such Automatic Door Opening and closing systems are very useful as you do not need a person to standby the door and open it whenever a guest comes. Also, since the doors are opened and closed only when a person approaches the door, there is significantly less loss of air conditioning.

LITERATURE REVIEW

“Automatic opening control system of Garage Door Based on AT89S52 Microcontroller” by Yanlin Tao. In this paper, an automatic opening control system of garage door is designed by using infrared sensor recognition Technology (AT89S52 Microcontroller) and corresponding reliable security measures. Just fixed the system in front of the windshield of your own car, automatic opening of garage door can be achieved when the car is driving near the garage. No need to modify the original garage control system. With low cost and high practicability. [1]

“Automatic Gate using Bluetooth technology (Open the gate with the strength of the Bluetooth signal on the smartphone)” by Kittipat Khreasarn, Kittikorn, at present, The Door is open by the key card or fingerprint identification of the user to order the system to open the door. The user also needs to carry a key card. This makes it inconvenient to use. The key card may be lost or forgotten. In addition, it is a fingerprint system, it also causes inconvenience to the user. These errors are caused by many factors. For example, the efficiency of dirty finger. This paper introduced Bluetooth technology, which is a device that publishes small data in a specific format using data display mode, which is commonly used to detect and monitor devices in the building. They can provide their device information and location. For this purpose, it is recommended to use technology that meets the following requirements. Low cost, low power consumption. High-precision, reliable and real-time Operation. Bluetooth is the primary device of wireless communication. [2]

“Identity Verification using Computer Vision for Automatic Garage Door Opening” by Rob G. J. Wijnhoven and Peter H. N. In this paper, they introduced Automatic identification of vehicles as part of an intelligent access control system for a garage entrance. Using a camera in the door, cars are detected and matched to the database of authenticated cars. Once a car is detected, License Plate Recognition (LPR) is applied using character detection and recognition. The found license plate number is matched with the database of authenticated plates. If the car is allowed access, the door will open automatically. [3]

“Hardware Implementation of Fire Detection, Control and Automatic Door Unlocking System for Automobiles” by J. Joy Mathavan, A.W. Faslan, N. U. A. Basith & W.V.S.D.

Wanigasinghe., The paper introduced, The systems available for the detection and control of fire accidents in automobiles. The system should be able to warn the driver, operates the fire extinguisher and unlock the door automatically. During an automobile fire, if there is a system to detect the fire and alerts the driver, then, the driver and passengers have a chance to save their life from the fire. Also, there must be systems to operate the fire extinguishers automatically during automobile fire incidents. [4]

“A digital automatic sliding door with a room light control system” by Adamu Murtala Zunger and Paul Obafemi Abraham- Attah. They introduced, the system in which, the model and design an automatic sliding door with a room light control system to provide the mentioned needs. This was achieved by considering some factors such as economy, availability of components and research materials, efficiency, compatibility and portability and also durability in the design process. This system works on the principle of breaking an infrared beam light, sensed by a photodiode. It consists of two transmitting infrared diodes and two receiving photodiodes. The first one is for someone coming in and the second one is for someone going out of the room. [5]

EXPERIMENTAL SETUP

Block Diagram

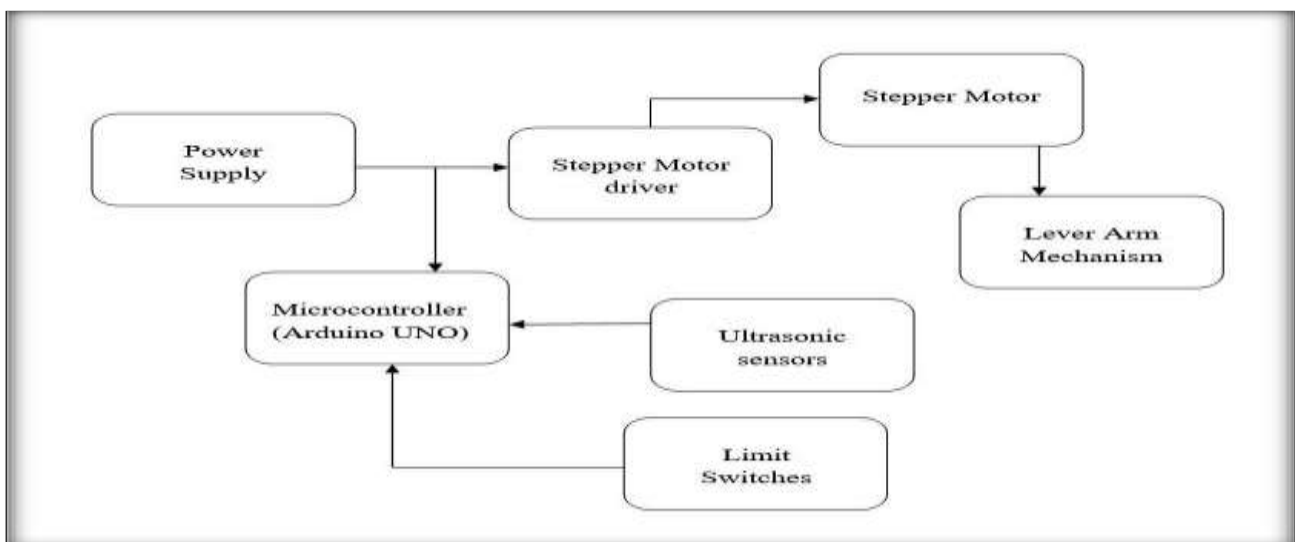

Fig. 3.1 Block Diagram

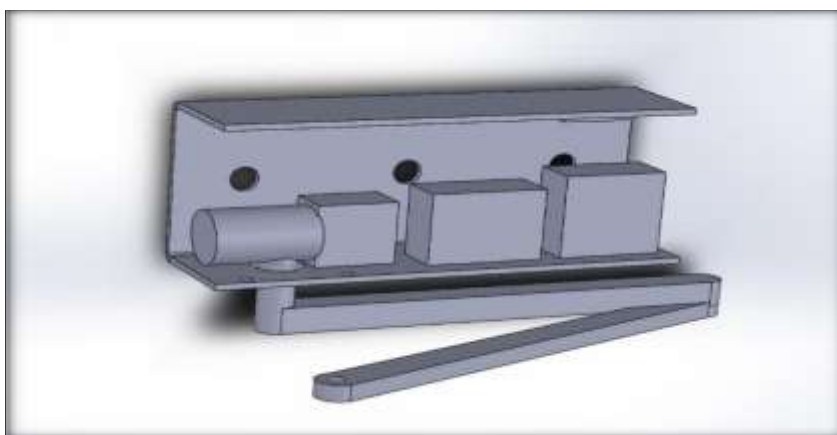

Fig. 3.2 Proposed 3D Model

Construction

The basic design for automation is consist offollowing component.

Table-1: Component of the project

Sr. No.	Component	Quantity
1	Stepper Motor	1
2	Worm And Worm Gear Box	1
3	Lever Arm	1
4	Ultrasonic Sensor	2
5	Driver Module	1
6	24V, 15A Power Supply	1
7	Arduino Uno	1
8	Coupling	1
9	Limit Switches	2

Working

The working of the Automatic Door Opener System using Arduino and Ultrasonic Sensor is very simple. When the Ultrasonic Sensor detects any motion of a person, its Data OUT Pin will become HIGH. As this pin isconnected to the Arduino, it will detect this HIGH Signal and understands that there isperson approaching the door Arduino then immediately activates the Motor Driver module to rotate the lever arm which is linkagebetween motor and door, as a result of this thedoor gets open. After some time (about 2 to 5 seconds in this project), the Arduino will once again activate the Motor Drive to rotate motorin anticlockwise direction at an angle taken foropening the door to close the door.

DETAILS OF COMPONENTS

Motor

As torque require to open the door is 9.5353

N.m which is equivalent to 10 N.m, but there is no stepper motor for a calculated. So for increase torque as much torque we have to useworm and worm gear box.

By considering gear box wen have selected **23kg-c.m** stepper motor (NEMA 23) which require 24 volt and 15A input supply having stepped angle 1.8 degree. Stepper motorhaving higher accuracy than other motor like D.C motor.



Fig. 5.1 Stepper motor (NEMA 23)

Lever Arm

Lever Arm Mechanism is act as an actuator in order to meet our objectives of work. Length of lever is taken as the required for width of door. One end of lever is fixed to the output shaft of gear and another end is pivoted to one side of door. Lever arm is responsible for the turning of door through less than 90 degrees as result of this door get open or close.

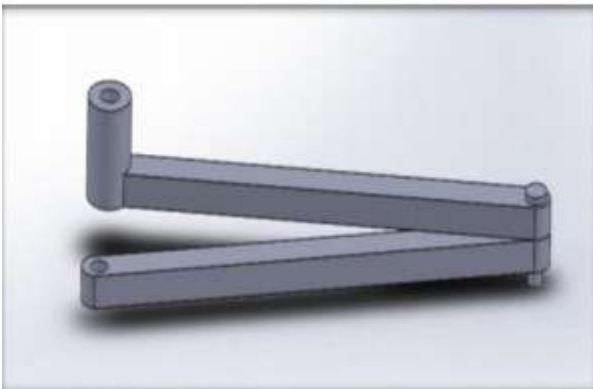

Fig 5.2 Lever arm

Ultra sonic sensor

Detecting human motion is done with the help of Ultrasonic Sensor. Ultrasonic Distance Sensor provides very short (2C.M) to long- range (4M) detection and ranging. The sensor provides precise and stable non-contact distance measurements from about 2cm to 4 meters with very high accuracy. It can be easily interfaced to any Arduino.



Fig 5.3 Ultra sonic sensor

Driver module

The motor driver module is used to drive the stepper motor. The driver module suited for our motor is DM860H motor driver. The DM860 is a fully digital stepper drive developed with advanced DSP control algorithm based on the latest motion control technology. It has achieved a unique level of system smoothness, providing optimal torque and nulls mid-range instability. Compared with traditional analog drives, DM860 can drive a stepper motor at much lower noise, lower heating, and smoother movement. Its unique features make DM860 an ideal choice for high requirement applications.

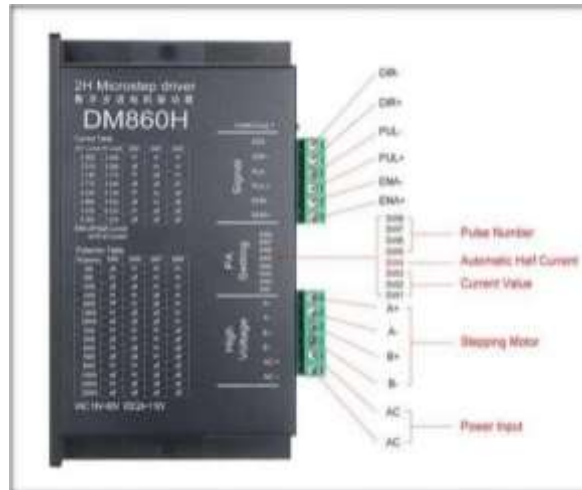

Fig 5.4 Driver module

Power supply

Power supply is used for giving electric power to the motor, driver module and Arduino UNOboard. The motor required 12 V and 5 Amp. current as an input power, so that we are going to use 12V, 5A Power Supply. This power supply requires 90 to 240 Volts as an input power.



Fig 5.5 Power supply

Results

Door gets automatically opened whenever a person comes in the sensing range of the sensors. Direct physical contact for opening and closing the door got eliminated. During the testing of the model we got the following results.

Table No. 6.1 Results

Trial No.	Time Required for Opening the Door	Time Required for Closing the Door
1	15 sec	11 sec
2	14 sec	10 sec
3	15 sec	10 sec
4	15 sec	10 sec
5	15 sec	10 sec

Arduino UNO

In this project, Arduino UNO acts as the maincontrolling part. It reads the data from theUltrasonic Sensor and activates the Motor Driver based on the data from the Ultrasonic Sensor.

TESTING AND RESULTS

Testing

Testing of the model is the final stage of our work to check whether the objectives set by us are accomplish or not. After the complete assembly of the model for ensuring the proper working of our model we gone through two stages of testing. we move further for testing of the model this testing is in two stages.

CONCLUSION AND FUTURESCOPE

Direct physical contact of peoples for opening and closing the door got eliminated thereby, it will help to prevent or reduce the spreading of pandemic disease COVID-19. We have Successfully design, manufactured, assembled and implemented our project to ensure the proper working based on our set of objectives.

Our project can be useful for physically handicapped people to open or closing the door at public places such as railway station waiting model works properly.

In second stage of testing we test our model by installing it on with actual application i.e. on the door. After the first stage of testing, by doing some modifications we done testing of our model finally on the actual door,rooms,ailway doors,by making somemodifications in the mechanism.

REFERENCE

- [1] “Automatic opening control system of Garage Door Based on AT89S52 Microcontroller” by Yanlin Tao
- [2] “Automatic Gate using Bluetooth technology (Open the gate with the strengthof the Bluetooth signal on the smartphone)”by Kittipat Khreasarn, Kittikorn,
- [3] “Identity Verification using Computer Vision for Automatic Garage Door Opening” by Rob G. J. Wijn hoven and Peter H. N.

[4] **“Hardware Implementation of Fire Detection, Control and Automatic Door Unlocking System for Automobiles”** by J. Joy Mathavan, A.W. Faslan, N. U. A. Basith & W.V.S.D. Wanigasinghe

[5] **“A digital automatic sliding door with aRoom light control system”** by Adamu Murtala Zunger and Paul Obafemi Abraham- Attah.