

# Smart Grid Energy Meter using GSM Technology

Pradeep Kumar Guru<sup>1</sup>, Soumya Ranjan Prusty<sup>1</sup>, Debi Prasad Mohanty<sup>1</sup>, Rashmi Ranjan Das<sup>2</sup>

<sup>1</sup>Department of Electrical Engineering, Gandhi Institute For Education & Technology, Khurda, Odisha, India

<sup>2</sup>Department of Electrical Engineering, Suddhananda Engineering And Research Center, Bhubaneswar, Odisha, India

**Abstract**— Now a Days lot of miss uses and miss handling of energy meter is happening someone will theft the power by connecting in the input of energy meter. The payment of bill by using the energy doing the corruption in it, so to overcome all the problem the “Online Automation Energy Meter “is used in this system the reference power will be added, if the power is exceed the reference power automatically the data will be send to the BESCOM people later those will replay to the particular customer that they used the power above the consumed power. If the metal casing is opened then the message will be send to the BESCOM people. Then they will send that why the metallic case is opened ,the customer will have to give the replay for the metallic case .

If anyone tries to open the case of the energy meter then it will send SMS to BESCOM that someone is opening the energy meter.

If every month amount is generated by BESCOM people they will send the amount and payment date if they will not pay they have to cut the power by using online, if they paid then automatically the will connect the power.

There is option to control the Electrical devices using the SMS protocol.

*Index Terms* — *Energymetr, Bescom, Gsm.*

## I. INTRODUCTION

Over the past years electric energy meters have undergone phenomenal changes and are expected to become even more sophisticated , offering more and more services.

The electromechanical based energy meters are rapidly being replaced by digital energy meters which offer high accuracy and precision.

Final year B.Tech

- Sushmitha.S
- Kumari Kavita Ambiger
- Jaishree.B.M
- K Saravanan

Now the generation of electric energy meters is that of AMRs. Various features offered by AMR are given below:

- 1) Higher speed
- 2) Improved load profile
- 3) Automatic billing invoice
- 4) Real time energy cost
- 5) Alarm warning
- 6) Remote power switches ON/OFF

## OBJECTIVES OF ENERGY METER:

- Programming of remote modem with AT commands
- Interfacing programming chip with the computer
- Interfacing programming chip with energy meter
- Sending message from the MODEM to remote mobile phone.

## Methodology:

*Methodology* is intended to present an overview of pre-paid energy meter, which can control the usage of electricity on consumer side to avoid wastage of power. Since there is need to utilize energy in better and efficient way, so this pre-paid meter proves to be a boon in the power sector. The major drawback of a post paid system is that there is no control of usage from the consumer's side. There is a lot of wastage of power due to the consumer's lack of planning of electrical consumption in an efficient way. Since the supply of power is limited, as a responsible citizen, there is a need to utilize electricity in a better and efficient way. The distribution company has to receive huge amounts in the form of pending bills, which results in substantial revenue losses and also hurdles to modernization because of lack of funds. The billing system is minimally able to detect power theft and even when it does at the end of the month. Also, the distribution company is facing many problems in terms of losses. The distribution company is unable to keep track of the changing maximum demand for domestic consumers. The consumer is facing problems like receiving due bills for bills that have already been paid as well as poor reliability of electricity supply and quality even if bills are paid regularly. The remedy for all these problems is to keep track of the consumers load on a timely basis, which will help assure accurate billing, track maximum demand, and detect online theft. These are all the features to be taken into account for designing an efficient energy billing system. The present project incorporates these features to address the problems faced by both the consumers and the distribution companies.

The method used to carry out here is the principle of serial communication in collaboration with embedded system. The project has a electric meter which will work and a GSM modem which is the latest technology used for communication between MODEM and embedded systems.

The modem will send a message as and when desired to the electricity officials through Subscriber Identity Module inserted inside the MODEM.

## II. EXISTED WORK

The basic unit of measure of electric power is the Watt. One thousand Watts are called a kilowatt. If you use one thousand Watts of power in one hour you have used a kilowatt-hour (kWh). Your electric utility bills you by the kWh.

The standard electric power meter is a clock-like device driven by the electricity moving through it. As the home draws current from the power lines, a set of small gears inside the meter move. The number of revolutions is recorded by the dials that you can see on the face of the meter. The speed of the revolutions depends on the amount of current drawn; the more power consumed at any one instant, the faster the gears will rotate.

When reading an electric meter, read and write down the numbers as shown on the dials from right to left. When the pointer is directly on a number, look at the dial to the right. If it has passed zero, use the next higher number. If the dial has not passed zero, use the lower number. Record the numbers shown by writing down the value of the dial to your extreme right first and the rest as you come to them. Should the hand of a dial fall between two numbers, use the smaller of the two numbers.

Note that some newer electric meters use digital displays instead of dials. The difference between one month's reading and the next is the amount of energy units that have been used for that billing period.

You may also wish to contact your local utility company for more information about reading your electric meter.

## III. RELATED WORK

Global System for Mobile Communication (GSM) is the world's most popular standard for mobile telephony systems. GSM is used by over 1.5 billion people all over the world. GSM also pioneered the low cost implementation of the Short Message Service (SMS) which allows parties to exchange delay tolerant short text messages. The popularity and coverage of cellular networks allows the use of SMS service.

However there are certain questionable issues regarding the GSM network such as scalability, reliability and security especially under high load. According to the analysis of real data taken from a real GSM network in India, SMS delivery success rate is found to be 94.3%. Of these successfully delivered messages, 73.3 arrived to their destination within 10 seconds. About 5% of them required more than 1 hour to reach the destination.

Using SMS for AMR will certainly increase the flow of messages tremendously. GSM uses several cryptographic algorithms for security. The development of UMTS introduces an optional Universal Subscriber Identity Module (USIM), which uses a longer authentication key to give greater security, as well as mutually authenticating the network and the user.

## IV. SYSTEM MODEL

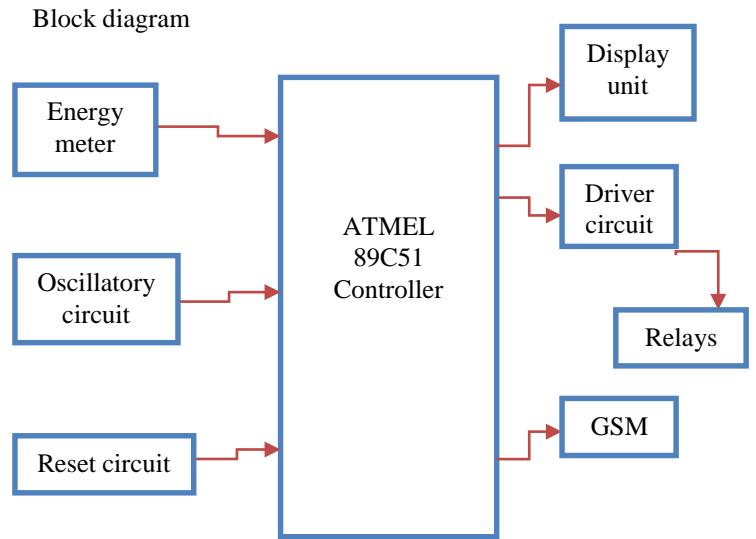

### MESSAGE FORMATE:

Parameter	From	To	Message formate
If reference power exceed	Energy meter	BESCOM	"The power is exceed intimate to customer"
	BESCO M	Customer/En ergy meter	"Two message that " you meter power is exceed please pay the money" if they not pay the money the power will cut off using protocol"9-0"
Mater cap	Energy meter	BESCOM	"the meter cap is removed please check the energy meter"
	BESCO M	Customer	"check the meter cap and fix the problem if any power loss the penalty will be issued"
Amount Payment	Energy meter	BESCOM	"the meter reading is xxx date is exceed"
	BESCO M	Customer	"the amount is xxxx for meter reading xxx need to pay on xx/xx/xxxx if not paid meter will be off" to switch on the meter the command will be "9-1"
Electronic Device control	Customer	Energy meter	For each device there will be two command as follow "1-0" to off "1-1" to on "2-0" & "2-1" .....etc

### PROJECT OUTLINE

- A brief introduction to internal architecture of micro controller.
- An over view of programming of micro controller.
- An overview on C language.
- An overview on interfacing LCD
- An overview of GSM.

- An overview on interface of switches ,Relays ,Energy meter and led.

#### GSM (Global System for Mobile Communication)

GSM has been the backbone of the phenomenal success of mobile communication in the previous decade. Now at the dawn of true broadband services, GSM continues to evolve to meet new demands. GSM is an open, non proprietary system with international roaming capability.

GSM was originally known as Groupe Speciale Mobile but nowadays it is commonly referred as Global System for Mobile Communication. It is a set of standards developed by the European Telecommunications Standards Institute (ETSI) to describe technologies used for second generation digital communications, commonly referred as 2G technologies.

It was developed as a replacement to the first generation analog communications. It originally described a digital circuit switched network optimised for full duplex voice communications.

The standard was expanded over time to include first circuit switched data transfer, then packet data transport via GPRS (General Packet Radio Service). Packet data transmission speed were later increased with the help of EDGE (Enhanced Data Rate for GSM evolution) technology. The GSM standard is succeeded by third generation (3G) UMTS standard developed by the 3GPP.

#### *TECHNICAL DETAILS:*

GSM is a cellular network which means that compatible devices connect to it by searching for cells in the immediate vicinity.

There are five different cell sizes in a GSM network viz. Macro, Micro, pico, femto and umbrella cells. The coverage area of each cell varies according to the implementation environment. Macro cells can be regarded as cells where base station is installed on a mast or building above roof top level. Micro cells are those in which base station is installed below the average roof top level. They are typically used in urban areas. Pico cells are the cells whose coverage area is a few dozen metres in diameter and are mainly used indoors. Femto cells are cells designed for use in residential or small business environment and connect to the service provider's network via a broadband internet connection. Umbrella cells are used to cover shadowed regions of smaller cells and fill in gaps in coverage between those cells.

#### *Modulation Used:*

The modulation used in GSM is Gaussian Minimum Phase Shift Keying (GMSK), a kind of continuous phase frequency shift keying. In GMSK the signal to be modulated on the carrier is first smoothed with a Gaussian low-pass filter prior to being fed into a frequency modulator which greatly

reduces the interference to neighbouring channels (adjacent channel interference).

#### *GSM Carrier Frequencies used:*

GSM networks operate in a number of frequency bands (separated into GSM frequency range for 2G and UMTS frequency range for 3G). Most 2G GSM networks operate in the 900 MHz or 1800 MHz frequency bands. Where these bands are already occupied 850 MHz or 1950 MHz frequency bands are used e.g. in USA and Canada. In rare cases 400 and 450 MHz bands are allocated because they were earlier used for first generation communications. Most of the 3G GSM networks operate in the 2100 MHz frequency band. Regardless of frequency selected by an operator, it is divided into time slots for individual users to use. This allows eight full rate or sixteen half rate speech channels per radio frequency. These eight radio slots are grouped into a TDMA frame. The channel data rate for all 8 channels is 270.833 Kbps and the time duration is 4.615 ms.

#### *Power Supply*

In alternating current the electron flow is alternate, i.e. the electron flow increases to maximum in one direction, decreases back to zero. It then increases in the other direction and then decreases to zero again. Direct current flows in one direction only. Rectifier converts alternating current to flow in one direction only. When the anode of the diode is positive with respect to its cathode, it is forward biased, allowing current to flow. But when its anode is negative with respect to the cathode, it is reverse biased and does not allow current to flow. This unidirectional property of the diode is useful for rectification. A single diode arranged back-to-back might allow the electrons to flow during positive half cycles only and suppress the negative half cycles. Double diodes arranged back-to-back might act as full wave rectifiers as they may allow the electron flow during both positive and negative half cycles. Four diodes can be arranged to make a full wave bridge rectifier. Different types of filter circuits are used to smooth out the pulsations in amplitude of the output voltage from a rectifier. The property of capacitor to oppose any change in the voltage applied across them by storing energy in the electric field of the capacitor and of inductors to oppose any change in the current flowing through them by storing energy in the magnetic field of coil may be utilized. To remove pulsation of the direct current obtained from the rectifier, different types of combination of capacitor, inductors and resistors may be also be used to increase to action of filtering.

#### *Keil Software:*

KEIL Micro Vision is an integrated development environment used to create software to be run on embedded systems (like a microcontroller). It allows for such software to be written either in assembly or C programming languages and for that software to be simulated on a computer before being loaded onto the microcontroller. The software used is c programming.

$\mu$ Vision3 is an IDE (Integrated Development Environment) that helps write, compile, and debug embedded programs. It encapsulates the following components:

- A project manager.
- A make facility.
- Tool configuration.
- Editor.
- A powerful debugger.

To create a new project, simply start micro vision and select "Project"=>"New Project" from the pull-down menus. In the file dialog that appears, a filename and directory was chosen for the project. It is recommended that a new directory be created for each project.

As several files will be generated. Once the project has been named, the dialog shown in the figure below will appear, prompting the user to select a target device. The chip being used is the "AT89S52," which is listed under the heading "Atmel". Next, Micro Vision was instructed to generate a HEX file upon program compilation.

A HEX file is a standard file format for storing executable code that is to be loaded onto the microcontroller. In the "Project Workspace" pane at the left, right-click on "Target 1" and select "Options for 'Target 1' ".Under the "Output" tab of the resulting options dialog, ensure that both the "Create Executable" and "Create HEX File" options are checked. Then click "OK". Next, a file must be added to the project that will contain the project code. To do this, expand the "Target 1" heading, right-click on the "Source Group 1" folder, and select "Add files..." Create a new blank file (the file name should end in ".c"), select it, and click "Add." The new file should now appear in the "Project Workspace" pane under the "Source Group 1" folder.

Double-click on the newly created file to open it in the editor. To compile the program, first save all source files by clicking on the "Save All" button, and then click on the "Rebuild All Target Files" to compile the program as shown in the figure below. If any errors or warnings occur during compilation, they will be displayed in the output window at the bottom of the screen.

All errors and warnings will reference the line and column number in which they occur along with a description of the problem so that they can be easily located . When the program has been successfully compiled, it can be simulated using the integrated debugger in Keil Micro Vision. To start the debugger, select "Debug"=>"Start/Stop Debug Session" from the pull-down menus.

At the left side of the debugger window, a table is displayed containing several key parameters about the simulated microcontroller, most notably the elapsed time (circled in the figure below). Just above that, there are several buttons that control code execution.

The "Run" button will cause the program to run continuously until a breakpoint is reached, whereas the "Step Into" button will execute the next line of code and then pause (the current position in the program is indicated by a yellow arrow to the left of the code).

#### *INTERFACES USED*

- Energy meter interfacing.
- LCD Interfacing.
- GSM interfacing
- Oscillator and Reset interfacing
- switches, led interfacing with micro controller Relay interfacing.

#### *SOFTWARES USED*

- A Cross compiler for compiling and linking the code written for AT89C51.
- Serial communication software for downloading code to AT89C51.
- Operating system: Windows XP.

#### *Advantages:-*

- The system is used to identify the fault connection.
- It will send sms when green power is consumed . And this will intimate to the consumer.
- If any one try to open the energy meter it eill intimate to bescom. So this is highly secure to thirft the power.
- Accuracy is more.
- The load will be control by the consumer if the load is in on any where by using SMS.
- Protocal is very easy to operate/
- High accuracy over a wide current dynamic range.
- Reliability and robustness.
- Automatic Meter Reading.
- More easily enable new functionalities.
- Tamper proofing.
- Easily reconfiguration, upgrade .

#### *Application:-*

- The system is used in home automation system.
- The system is used in base stations.
- This system is use in the power controlling system.
- Industrial control, Medical systems, Access control, Point-of-sale, Communication gateway, Embedded soft modem, General purpose applications.

#### *REFERENCES*

- [1] Yujun Bao and Xiaoyan Jiang, "Design of electric Energy Meter for long-distance data information transfers which based upon GPRS", ISA 2009. International Workshop on Intelligent Systems and Applications, 2009.
- [2] H.G.Rodney Tan,C.H. Lee,V.H.Mok,"Automatic power meter reading system using GSM network", The 8 Conference (IPEC 2007). International Power Engineering
- [3] Vivek Kumar Sehgal,Nitesh Panda, Nipun Rai Handa, "Electronic Energy Meter with instant billing",UKSim Fourth European Modelling Symposium on Computer Modelling and Simulation.
- [4] Bharath P, Ananth N, Vijetha S, Jyothi Prakash K. V. , "Wireless automated digital Energy Meter", ICSET 2008.
- [5] Subhashis Maitra, "Embedded Energy Meter- A new concept to measure the energy consumed by a consumer and to pay the bill", Power System Technology and IEEE Power India Conference, 2008.

- [6] T El-Djazairy, B J Beggs and I F Stewart, " Investigation of the use of the Global System for Mobile Communications (GSM) network for metering and load management telemetry", Electricity Distribution. Part 1: Contributions. CIRED. 14th International Conference and Exhibition on (IEE Conf. Publ. No. 438).
- [7] Li Kaicheng, Liu Jianfeng, Yue Congyuan, Zhang Ming. "Remote power management and meter-reading system based on ARM microprocessor", Precision Electromagnetic Measurements Digest, 2008. CPEM 2008. Conference on Digital Object Identifier.
- [8] M.P Praveen, "KSEB to introduce SMS-based fault maintenance system", The Hindu News on 26/06/2011, <http://www.hindu.com>.