

FIG. 1 – BLOCK DIGRAM OF PROJECT

VI. APPLICATIONS OF EMBEDDED SYSTEMS

- Army, Military and aerospace embedded software applications and Telecom Applications
- Industrial control system software
- Decoding the complexity of applications.
- Reducing of production design time.
- Real time management of processing data.
- Intelligent, autonomous sensors.

VII. HARDWARE TESTING

CONTINUITY TEST: In hardware and electrical devices, a coherence test reviews on the flow of electric current in the circuit, to see whether the circuit is fully connected or not. This test is run using and analysing a minor voltage (series wiring with a LED or noise producing speakers) over the desired path . if under any condition flow is being stopped, like due to excessive resistance, conductor default, the circuit is remained “open”

POWER ON TEST: This testing is done at various terminals to analyze the voltage at respective nodes, that voltage is of necessity or not. In this test, a multi meter and connected in voltage mode. In view, no microcontroller at that time is connected to the system. Primarily, we check the yield of the transformer, to get the required alternating current voltage of 12v. On that point flow of voltage is being transmitted of intensity flexibility. This test is managed without use of microcontroller, in such a case that there is any inordinate voltage present in the framework, it might prompt flow in the Microcontroller. After checking for the need of regulator has been done i.e., if output of 5v and reactive voltage 12v is present or not. [7]

VIII. LAYOUT OF THE PROJECT

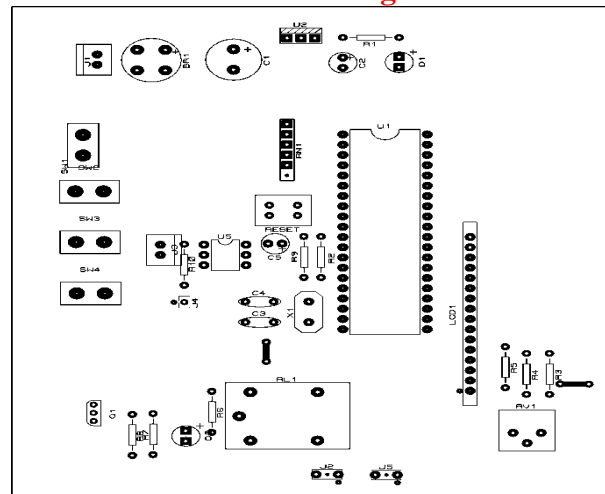

FIG.2. LAYOUT OF THE PROJECT

IX. ADVANATGES

- To monitoring and controlling of domestic Energy meter of electric meter by 8051 microcontroller
- As this contain the use of the microcontroller unit that continuously displays, processes and records the energy meter reading in its permanent (nonvolatile) memory Location and shows output on display.
- This system also makes use of display of instant tariff and units consumed by appliance and all power usage by consumer.
- Technologies more precise and accurate, error free, time efficient etc.
- It saves the time and efforts utilized in auditing enabling AT89S52 microcontroller. .

X. SYSTEMATIC DIAGRAM OF PROJECT

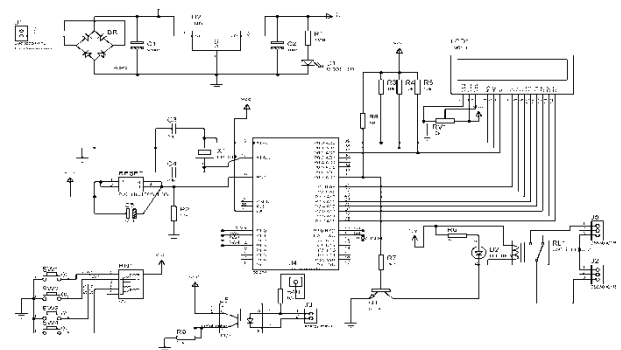

FIG.3. SYSTEMATIC DIAGRAM OF PROJECT

XI. BLOCK DIAGRAM OF MICROCONTROLLER AT89S5

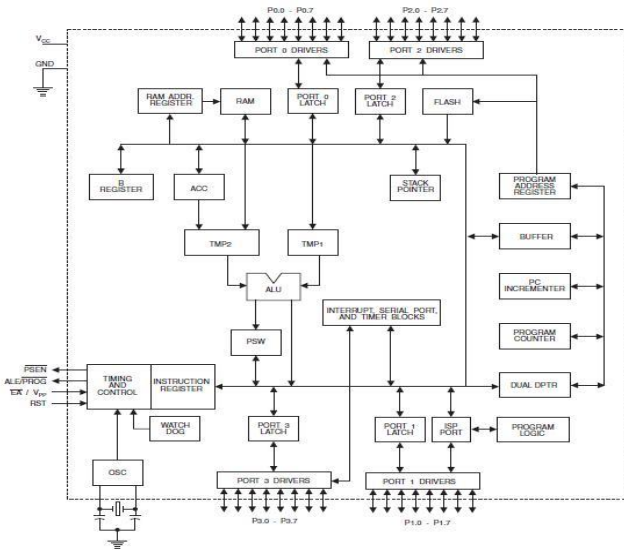

FIG. 4. . BLOCK DIAGRAM OF MC AT89S52
XII. MICROPROCESSOR AT89S52

It consumes less power, 8-bit memory which is programmable.

One chip is present allows memory of the system to rest within the system or via standard memory system that is not set down. By integrating an 8-bit convergent controlled processing unit with organized in system monolithic chip, ATMEL AT89S52 is a strong impactful microcontroller, easy to use solution for an embedded control application. AT89S52 offers two standard features: 8k Flash bytes, 256 bytes of RAM, 32 I / O, Watchdog timer, 2 data pointers, three timers / counters of 16-bit, a six-dimensional weird six-vector, a full serial duplex port, an one oscillator built on chip, a clock circuit. Moreover, AT89S52 operates at a frequency of zero and supports two energy saving modes and with inbuilt ability to do logic operations. It has flash memory. These are characteristics of the microprocessor AT89S52, IDLE mode stops many ports for further functioning, like eliminating RAM content, serial port and other chips and pins programs when needed. [2]

XIII. LCD DISPLAY

Parallel Port, example does not use the Bi Side feature found in the new ports, thus it should be very effective, if not all Parallel Ports. However it does not indicate the use of Portus Mode as an alternate port in parallel is connected to the 16 Character x 2 Line Module. This kind of modules are very random in use, and they are easy to work on, because the necessary runs are on board.[5]

Functions of LCD:-

- Very compact and light
- Low power consumption
- There is no denying geometry
- Little or no flicker counting on backlight technology
- Not affected by the new screen
- No difficulties are form during repairing and servicing
- It can be made in almost any size or shape
- No decision limit theory

XIV. INTERFACING BETWEEN CONNECTOR AND MICROCONTROLLER AT89S52

In this connector, there are 9 pins present, 5 pins above and 4 pins below. These are basically used in PC applications. Various types of connector are present such as HD, DB4, DB5, MD, MD50, MD68, and high density, and HD14 has 15pins Various other connectors like High density DB connector is very similar to regular one. In this type pins are packed so close to one another, it's also named as HD connector. It has 3 rows of pins rather than 2 schemes. These are connected in parallel. Pins are more secured in parallel type rather than other ones.

DB Connector for Micro, This link is smaller than the standard D-sub, which has smaller pins than those used on HD connectors. MD is also commonly referred to as "pitch" DB.

MD connectors uses latch chips or thumbscrews as a binding mechanism.

DB connectors are referred as type of connector which is used to hold many numbers of pins. HD 15 connector used by monitor screens are summed up with HD14, which contains of 15 pins, and still knows as HD15 connector. [5]

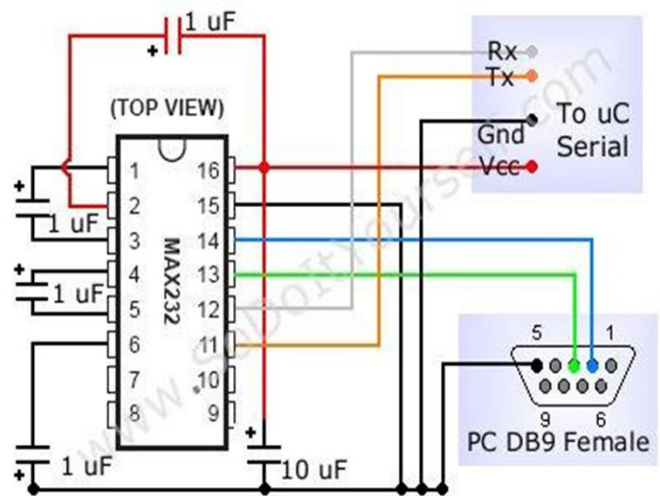

XIV. ELECTRIC METER

Electric meters are usually measured in charge units, which is usually a kilowatt hour. Regular readings of electrical meters establish the charge cycles and the energy used during the cycle.

In settings where energy savings are sometimes desired, meters can measure demand, maximum power consumption during downtime. In some areas, electricity prices are too high at certain times of the day, to encourage a reduction in consumption. Also, in some places the meters can be transmitted to turn off unnecessary equipment.

The most common type of electric meter is an electronic mechanical meter of watt hour input. The electronic input meter works by calculating the change of aluminum disc that is rotated at a speed equal to the power. The amount of change in this way is proportional to the energy consumption. It uses small amount of power, usually around 2 watts.

One coil is arranged in such a manner that it develops magnetic flux proportional directly to voltage and the other produces magnetic flux at the current rate. The coil of voltage field is delayed by 90 degrees using the lagging of coil.[6]

XV. INTRODUCTION TO KEIL MICROVISION

This software is used to stimulate the compilers, bedbug the programs, kernels, debuggers, and provides the environment for microcontrollers to form an integrated environment for programmers for programming and various other board for coding, and work as. emulator for microcontrollers and microprocessors.

It constitutes of all the development tools required for the microcontroller specially 8051 type, it has its own architecture to work for software and coding development, it has databases, aggregator, ID Vision, memory formation tools to work in. Keil Vision is a cross compiler and it's easy to use.[4]

XVI. KEIL C CROSS COMPILER

These are the fundamental components and tools of cross compiler-

- IDE (Integrated Development environment)
- Simulator
- Debugger
- Programmer and project manager

- Linking tool and compiler

This compiler use these components to compile the program and assemble the coding and source code and use embedded c programming to form code and save it to the object code location and compiles the final program and make it run the programming.[9]

XV. PROGRAMMING VIA EMBEDDED C

The utilization of inserted processors is across the board in traveler vehicles, cell phones, clinical gadgets, aviation frameworks and protection frameworks, and regular family unit apparatuses like dish washers, TVs, clothes washers and video recorders currently incorporate at least one gadget.

Since primarily every implanted task has genuine cost limitations, they utilize ease processors like 8051 family gadgets considered in use of this procedure. These famous chips have exceptionally restricted assets, the majority of which have around RAM of 256 bytes and consequently the processor power accessible is multiple times however that of work area processors. Subsequently, creating implanted programming presents huge new snags for learned language software engineers. On the off chance that you are very brave understanding - in C language.[9]

XVI. ENERGY POWER SUPPLY

It's power supply comprising of a stage down transformer from 230V to changing 12V and 4 diodes to frame an extension rectifier which gives beat DC and afterward channels through an electrolytic capacitor from 470 μ F-1000 μ F. The separated DC is unrolled, and the ICLM 7805 is utilized to settle the 5V DC on its pin. The proportion of transformer essential voltage V1 to optional voltage V2 is administered by the equation $V1/V2 = N1/N2$. $N1/N2$ i.e, Changes that are not central.

The winding doesn't change in the optional V2 is straightforwardly relative to V1. On the off chance that the transformer spares 12V at 220 V, it gives 8.72 V at 160 V. At 270 V it is 14.72 V. Because of the AC voltage variety from 160V to 270V, the DC voltage controller yield at the contribution of the controller shifts from around 8V to 15V at 5V.

Additional small electrolytic capacitor of range of 10 μ F is used tom produces 5V direct current . An LED is associated with this 5 Volts point in the arrangement with a 330 Volts current breaking point resistor on the ground, for example a negative voltage to demonstrate the accessibility of the 5V power flexibly. An incongruent 12V point is utilized when required for different applications

It is a 6 pin Integrated sum of one light emitting diode and a transistor makes an optocoupler. Pin 6 of the transistor isn't commonly utilized and light radiates on the base-emitter junction it turns on and pin 5 turns to zero.

When contribution of the output of diode is considered as zero and opposite side is considered as one. If the point when rationalize as zero, it means light didn't fall on the transistor, At the point when rationale is given as 1, it means light falls on the transistor, makes it run on and connects it to the ground When Logic 1 is input, the light takes over the transistor, so it works, it turns on the transistor and it creates a short circuit so that the output logic is zero when collector is neutrally connected to ground.[7]

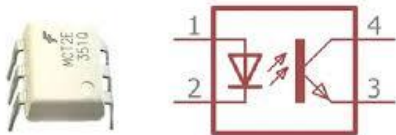

Fig. 6 - OPTOCOUPLER

XII. ACKNOWLEDGMENT

Our team is filled with gratitude towards our guide “Dr. Mohd Shahid” who guided us to reach our full potential with end results in this project. with whom we learned about this particular topic in depth, we are thankful that we were under guidance of him, who helped us taking small steps in our projects and giving us confidence in every step. We are thankful to our project coordinator “Dr. Pinky Yadav” who made us learn details and reach our excellence.

We are also thankful to our Head of department “Dr. Danish Equbal” for giving us surroundings to learn more everyday and assisted in completion of our goal. This project helped us to learn more about practical knowledge through practical experiments and gave us new perspectives in electrical engineering.

XIII. CONCLUSION

It is concluded on this project that this project is made in such a way it has a instantaneous energy auditing system using AT89S52 microcontroller, to measure the units consumption and cost incurred by device use over given time. The feeded and initial data including energy tariff and the number of hour's device is to be used is input by auditor into the system. In respect to the system the system instantly shows the cost

and units consumed within no time. The result is provided very fast simultaneously allowing auditor to utilize time wasted in the energy audit . This project itself made of an instantaneous energy auditing system using AT89S52 microcontroller. This a most beneficial model to save both time and money and save cost spend on auditing. It is time efficient and as it's controller by Microcontroller, it's efficient overall.

REFERENCES

- [1] Pritee Mahajan, Sneha Tatia and Prachi Jadhav, "Smart Meter: An IOT Based Meter for Live Electricity Monitoring and Bill Payment", International Journal of Electrical Electronics and Computer Systems (IJECS), 2017.
- [2] S. Visalatchi and K Kamal Sandeep, "Smart energy metering and power theft control using arduino & GSM", Institute of Electrical and Electronics Engineers (IEEE), 2017.
- [3] S. Srikanthan and M. K. Mishra, "proteus software smart meter," IEEE Trans. Ind. Electron., vol. 57, no. 8, pp. 2768–2775, Aug. 2015.
- [4] Ashna.k , Sudhish N George. "GSM Based Automatic Energy Meter Reading System with Instant Billing" 978-1-4673-5090-7 IEEE 2013
- [5] A. Arif , Muhannad AI-Hussain, Nawaf AI-Mutairi, "Experimental Study and Design of Smart Energy Meter for the Smart Grid" 978-1-4673-6374-7 IEEE 2013
- [6] Adnan Rashdi, R. Malik, S. Rashid, A. Ajmal, S. Sadiq , "Remote Energy Monitoring, Profiling and Control Through GSM Network", International Conference on Innovations in Information Technology (IIT) 2012.

- [7] M.P Praveen, “KSEB to introduce SMS-based fault maintenance system”, The Hindu News on 26/06/2011, <http://www.hindu.com>.
- [8] https://en.wikipedia.org/wiki/Embedded_system
- [9] <http://www.keil.com/c51/c51.asp>