

# Electric Vehicles and its Battery Management

Mitali Dalabehera<sup>1\*</sup>, Sukanta Patra<sup>2</sup>, Sushree Swagatika Mahapatra<sup>3</sup>, Durga Prasad Mishra<sup>4</sup>

Department of MBA

<sup>1,2,3</sup>Gandhi Institute for Education and Technology, Baniatangi, Bhubaneswar

<sup>4</sup>Capital Engineering College, Bhubaneswar

\* Corresponding Author

**Abstract:** - Battery management systems (BMS) are used in electric vehicle to monitor and control the charging and discharging of rechargeable batteries which makes the operation more economical. Battery management system keeps the battery safe, reliable and increases the senility without entering into damaging state. In order to maintain the state of the battery, voltage, current, ambient temperature different monitoring techniques are used. For monitoring purpose different analogue/digital sensors with micro controllers are used. This paper addresses state of charge, state of health, and state of life and also maximum capacity of a battery, by reviewing all these methodologies, future challenges and possible solutions.

**Keywords:** Battery management system, state of charge, state of health, state of life.

## INTRODUCTION:

Electric vehicles (EV) are playing a key role because of its zero-emission of harmful gases and use of efficient energy. Electric vehicles are equipped by a large number of battery cells which require a effective battery management system (BMS) while they are providing necessary power. The battery installed in a electric vehicle should not only provide long lasting energy but also provide high power. Lead-acid, Lithium-ion, -metal hydride are the most commonly used traction batteries, of all these traction batteries lithium-ion is most commonly used because of its advantages and its performance. The battery capacity range for a electric vehicle is about 30 to 100 KWH or more.

Battery management system (BMS) makes decisions based on the battery charging and discharging rates, state of charge estimation, state of health estimation, cell voltage, temperature, current etc.

## PROPOSED METHODOLOGY:

Energy and environmental problems are the most dangerous problems faced by the world automotive industry.to overcome these problems world has accelerated to the new energy development.

## BATTERY MANAGEMENT SYSTEM (BMS):

Battery management system (BMS) is the crucial system in electric vehicle because batteries used in electric vehicle should not be get overcharged or over discharged. If that

happens, it leads to the damage of the battery, rise in temperature, reducing the life span of the battery, and sometimes also to the persons using it. It is also used to maximize the range of vehicle by properly using the amount of energy stored in it. Battery management system is essential for following reasons

1. Maintain the safety and the reliability of the battery
2. Battery sate monitoring and evaluation
3. To control the state of charge
4. For balancing cells and controlling the operating temperature
5. Management of regenerative energy

## BMS BLOCK DIAGRAM:

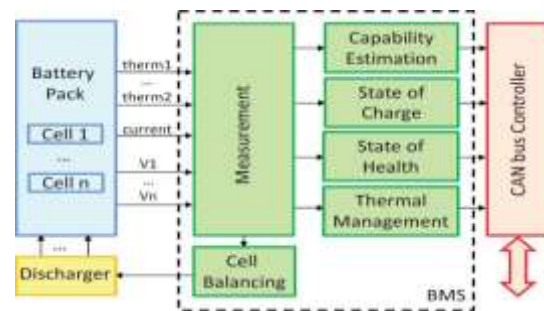

Figure 1 BMS block diagram

## STATE OF CHARGE ESTIMATION:

State of charge is defined as the available amount of battery as the percentage of rated capacity of the battery. State of charge gives a crucial support to battery management system to assess the state of the battery which helps the battery to operate within the safe operating range by controlling charging and discharging. It also increases the life span of the battery. State of charge cannot be estimated directly. It is calculated by using the equation

$$SOC = 1 - \frac{\int I dt}{C_n}$$

Where I =current and

C<sub>n</sub>= maximum capacity that the battery can hold

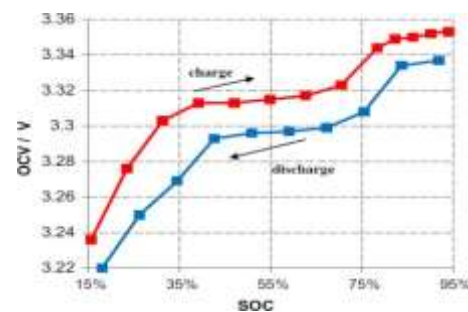

Figure 2 SOC during charging and discharging

There are various methods to estimate the state of charge. Following are the list of state of charge estimation method

1. Coulomb counting SOC estimation method
2. Fuzzy logic SOC estimation method
3. Impedance spectroscopy SOC estimation method
4. Kalman filtering SOC estimation method
5. Open circuit voltage SOC estimation method

Among all these various methods Kalman filtering method has been successful for the estimation of SOC for EV'S.

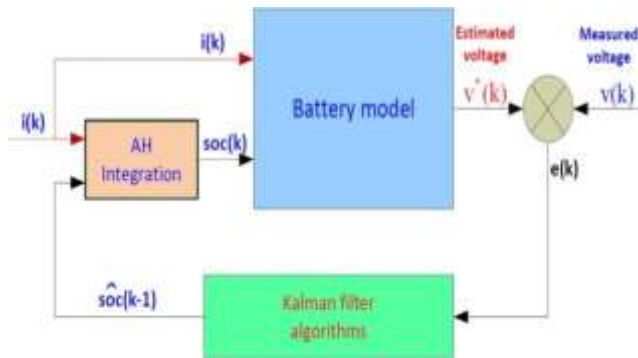

Figure3 Kalman filtering SOC estimation model

**State of Health Estimation:**

State of health estimation describes the state of the battery with respect to the newly manufactured battery. It gives information regarding the available amount of discharging capacity during its lifetime. The SOH in EV use to describe the ability to drive the specific distance.

According to Pattipati *et al* capacity fade and power fade together combined as health characteristics. capacity fade describes reduced driving range with a fully charged battery and power fade describes decrease in acceleration capacity. Power fade occurs when the impedance in the cell increases during aging. Hence, total impedance ( $R_{HF}+R_{tc}=R$ ). where  $R_{HF}$  and  $R_{tc}$  are frequency resistance and the transfer resistance.

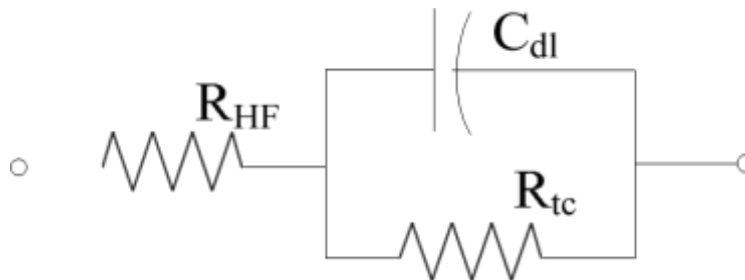

Figure 4 circuit model for a lithium-ion battery

$$P = \frac{I^2}{R}$$

$$\text{Power Fade} = 1 - \frac{I^2(t)}{I^2(0)} = 1 - \frac{P(t)}{P(0)}$$

$$\text{Capacity Fade (\%)} = 1 - \left( \frac{C(t)}{C(0)} \right) * 100$$

**STATE OF LIFE (SOL):**

The remaining useful life of a battery is known as SOL. RUL of a battery using a for different thresholds of capacity fade  $C(i)$  and power fade  $P(i)$  is given by equation

$$RUL(k) = h \left( \left\{ \frac{C(t)}{C(0)}, \frac{P(t)}{P(0)} \right\}_{t=1}^k \right)$$

where k is the k th week, approximately for an end-of-life criterion 23% power fade and 30% capacity fade is the RUL

**ESTIMATION OF MAXIMUM BATTERY CAPACITY:**

The maximum capacity of the battery describes the performance and future life of the battery. The maximum capacity of a battery is calculated by:

$$\text{Capacity} = \int I dt$$

Where I is the current

BATTERY CAPACITY ESTIMATION USING VARYING LOADS AND ENVIRONMENTAL TEMPERATURES:

Degradation of a battery depends upon charge and discharge cycle, environmental conditions and specific materials. The status of the battery is predicted when discharging at constant current and constant temperature. Here are few experimental factors of a lithium ion battery at different discharge rates and temperatures.

Discharge Rate	Temperature
0.5C (350 mA)	25 °C
0.5C (350 mA)	50 °C
1C (700 mA)	25 °C
1C (700 mA)	50 °C

Table 1 Experiment factors—different discharge rates and temperatures.

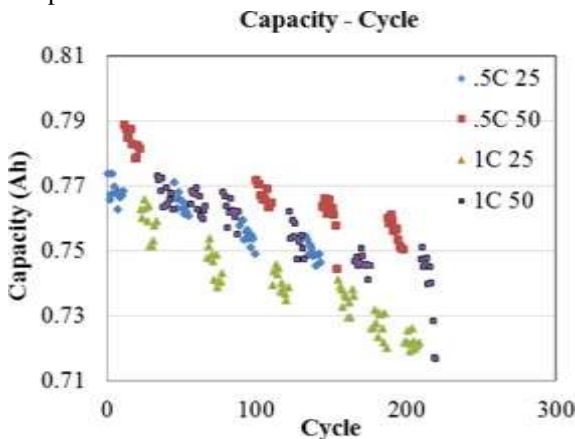

Figure 5 Discharging capability alternating at different discharge rates and at different temperatures.

CHARGING AND DISCHARGING OF LI-ION CELL USING BMS:

Lithium-ion batteries are highly reactive, smaller in weight and has the highest energy. Charging and discharging of lithium-ion batteries are very faster than the other batteries. Lithium-ion cells should be operated beyond its safe operating voltage range to avoid combination of many chemical reactions, rise in temperature which leads to cell venting and generation of fire. Hence, Battery management system (BMS) is used which allows the battery to operate with in their safety zone.

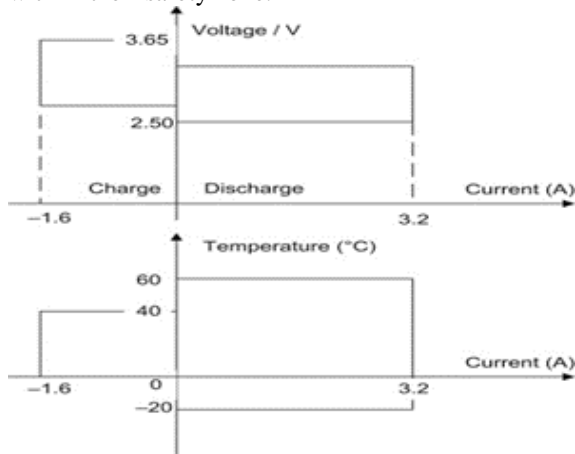

Figure 6 Safe operating area charging and discharging

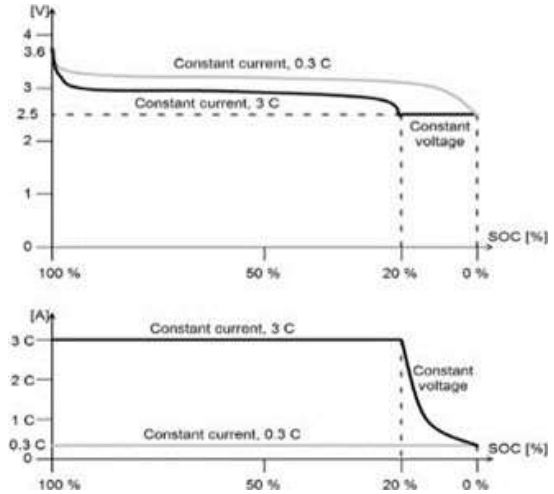

Figure 7 Charging and discharging of lithium-ion batteries

ADVANTAGES:

1. It improves the battery performance
2. It enhances the life span of battery
3. It controls the charging, discharging and temperature ranges and keeps them with in their range.
4. It predicts the batteries capabilities in near future

RESULT:

Based on this work, specific challenges faced by BMS and their solutions were presented as a foundation for future research. Based on the particular situation, different strategies can be applied to upgrade and optimize the performance of BMS in EV'S.

CONCLUSION:

In this way we are developing the system model for battery management in electric vehicle by controlling the crucial parameters such as voltage, current, state of charge, state of health, state of life, temperature. It is every important that the BMS should be well maintained with battery reliability and safety. This present paper focusses on the study of BMS and optimizes the power performances of electric vehicles. Moreover, the target of reducing the greenhouse gases can greatly be achieved by using battery management system.

REFERENCES:

- [1] H.J. Bergveld, Battery Management Systems Design by Modeling, 2001, ISBN 9074445-51-9
- [2] D. Bell, "A battery management system," Master's thesis, School Eng., Univ. Queensland, St. Lucia, Australia, 2000.
- [3] Sandeep Dhameja, Electric Vehicle Battery Systems, 2002, ISBN 0-7506-9916-7.
- [4] K. Shimitzu, N. Shirai, and M. Nihei, "On-board battery management system with SOC indicator," in Proc. Int. Electric Vehicle Symp., vol. 2, 1996, pp. 99–104.
- [5] Ng, K.S.; Moo, C.S.; Chen, Y.P.; Hsieh, Y.C. Enhanced coulomb counting method for estimating state-of-charge and state-of-health of lithium-ion batteries. *Appl. Energy* **2009**, *86*,1506–1511.
- [6] Pattipati, B.; Pattipati, K.; Christopherson, J.P.; Namburu, S.M.; Prokhorov, D.V.; Qiao, L. Automotive Battery Management System. In *Proceedings of IEEE AUTOTESTCON*, Salt Lake City, UT, USA, 8–11 September 2008; pp. 581–586.